



NEW
EXPANDED PROGRAM



EMUGE

COMPLETE LINE OF
THREAD MILLING SOLUTIONS

EMUGE Thread Milling Solutions



The science of thread milling is constantly evolving. EMUGE-FRANKEN offers manufacturers a wide range of tooling options and industry-leading designs with 5 distinct thread mill tool families. Each tooling group has been developed to address specific thread cutting requirements.

Thread milling is very flexible in terms of feed rates, thread size, programming approach and especially, the ability to control fit. A threaded hole is milled at a high RPM and rotates into a previously drilled hole. The machinist can adjust thread size using different cutting strategies, which is advantageous on tight tolerance threads.

Also, by using a solid carbide **THREADS-ALL** or **GIGANT-IC** carbide insert style thread mill, a single tool can be used to make a wide range of thread sizes. This reduces both the cost of tooling and tool change time. Additionally, a thread mill can create internal and external threads, right-hand and left-hand threads, as well as threads in very large holes.

Another benefit to thread milling is process stability. Unlike a standard tap, if a thread mill fails in the cut, it can easily be removed without the need for costly tap extractions or scrapping parts, making expensive parts ideal for thread milling. The **SHUR-THREAD** style of thread mills are full profile cutters offering high process stability.

Also, **THRILLER** style thread mills combine the drilling and thread milling process into one tool. These tools eliminate the need for tool changes and save machine tool carousel space. And **VARIO** full profile thread mills can produce multiple thread sizes in one specific pitch.

EMUGE-FRANKEN tooling experts are also available to help guide you through the tool selection process. Additional tool application resources are available at emuge.com.



Newly Expanded EMUGE-FRANKEN
manufacturing facility in Lauf, Germany
for thread mills and other tools

A Complete Range of Thread Mills

THREADS-ALL™



Product pages 4 - 13
Cutting Data page 41

THRILLER



Product pages 14 - 21
Cutting Data page 42

SHUR-THREAD™



Product pages 22 - 27
Cutting Data page 43

VARIO



Product pages 28 - 35
Cutting Data page 43

GIGANT-IC™



Product pages 36 - 39
Cutting Data page 43

THREADS-ALL™

Produce Full Bottoming Threads to Within 1 Pitch

The THREADS-ALL family of thread mills will have one or up to four cutting teeth depending on the model, and a reduced neck design. THREADS-ALL tools use a multiple 360° rotation in a corkscrew motion to produce the final thread form.

THREADS-ALL tools allows the user to control pitch diameter limits including 2B, 3B and oversize variants. These tools also produce full bottoming threads to within 1 pitch.

All THREADS-ALL thread mills require a pre-drilled hole prior to threading.

THREADS-ALL Thread Mills come in 2 PRODUCT TYPES:

Single Plane



Single Plane Multi-Row



- Sub-micro grain solid carbide with reduced neck design
- Coolant fed options (sizes 1/4" and greater)
- 2 x D and 3 x D length options available
- Miniature sizes starting at #0-80 / M1

THREADS-ALL Thread Milling Cycle

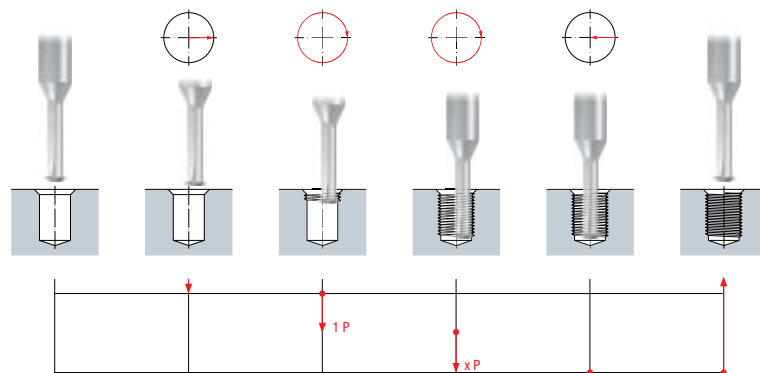

Cutting Data on page 41.

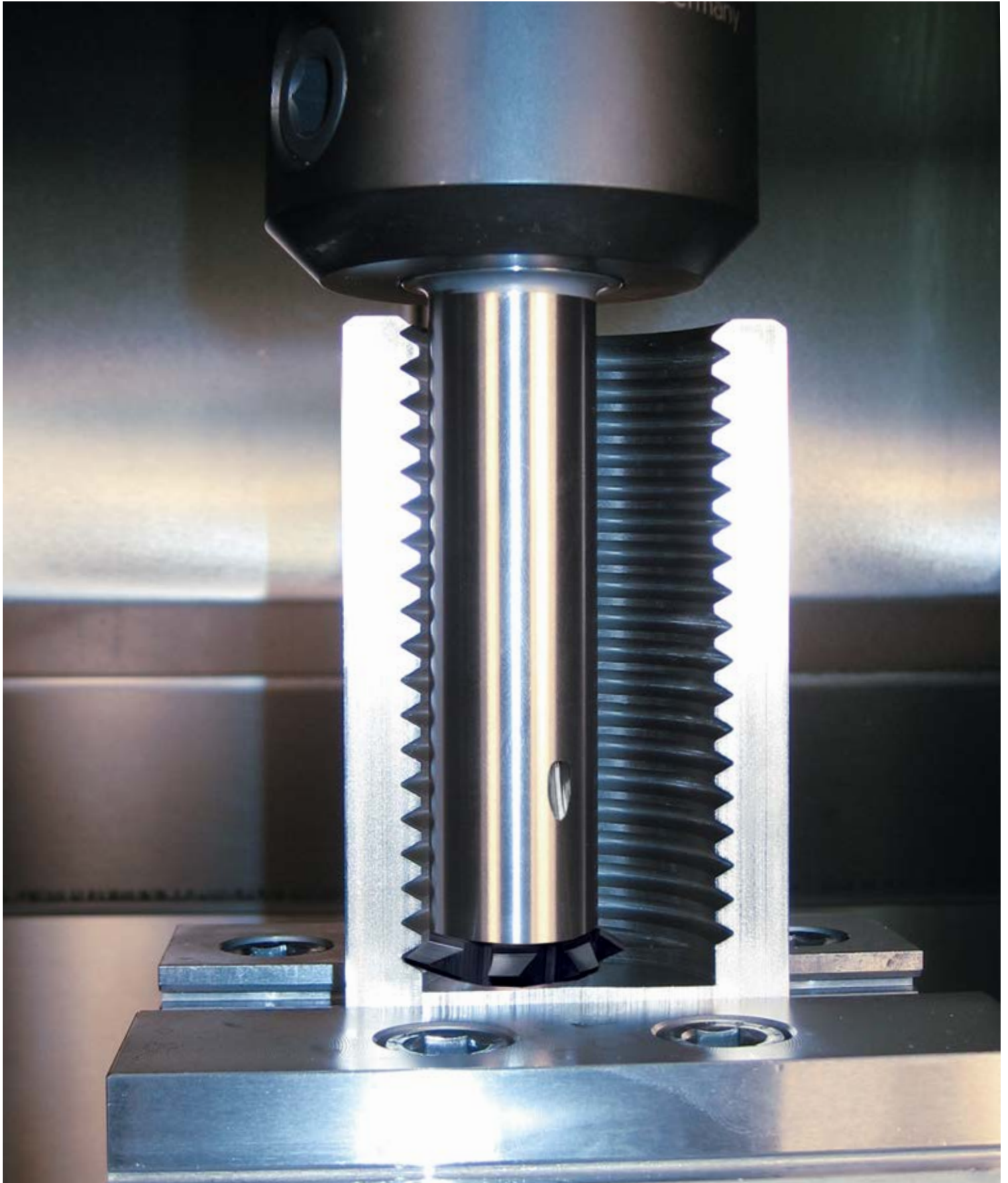

THREADS-ALL / HEADED, is ideal for large thread milling applications

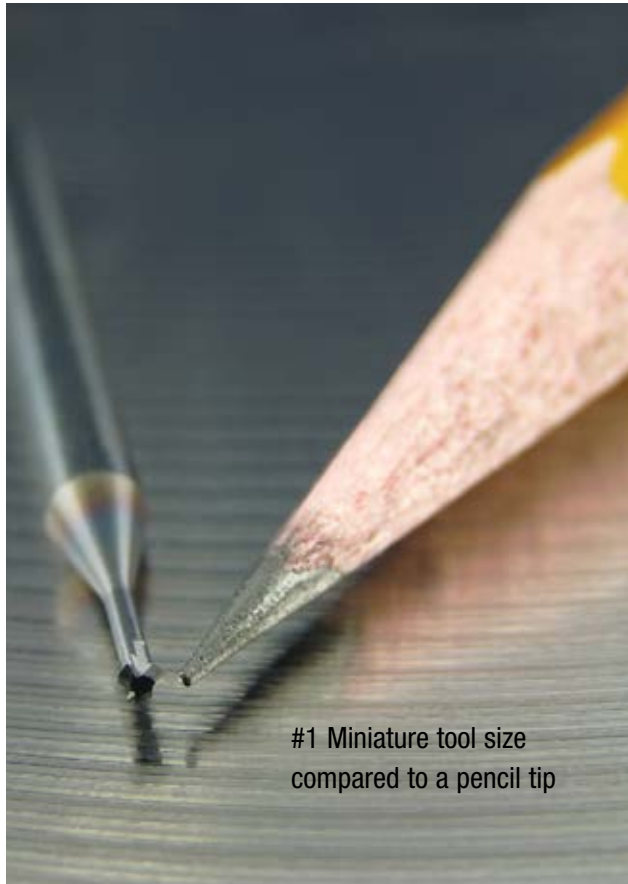

#1 Miniature tool size compared to a pencil tip

THREADS-ALL™

A Complete line of 2 x D Solid Carbide Thread Mills, plus 3 x D sizes for Maximum Reach

Miniature size thread mills provide a high-quality and dependable threading solution for a variety of difficult materials.

Standard sizes provide manufacturers a ready tooling solution which allows for quick adaptation to a variety of threading requirements in a wide range of materials.

- **Requiring only 8 stock standard tool sizes,** #10 • 1/4 • 5/16 • 3/8 • 7/16 • 1/2 • 5/8 • 3/4, it is now possible to produce 100+ commonly produced screw thread designations
- In addition, THREADS-ALL tools provide **total control over pitch diameter limits** including 2B • 3B • 3BG • and all oversize variants

Cutting Data on page 41.

2 x D - TICN COATED

	Tool Size	Thread Size								Cutter Dia. (in)	Cut Length (in)	# Flutes	OAL (in)	Shank Dia. (in)	Shank Type	EDP No.	
		UNC	UNF	STI UNC	STI UNF	UNEF	UNJC	UNJF	M								MJ
MINIATURE SIZES	#0	–	0-80	–	–	–	–	0-80	1.6 x .35	1.6 x .35	0.045	0.125	1	1 5/8	1/8	HA	GFS13706.5033
	#1	1-64	1-72	–	–	–	1-64	1-72	2 x .4	2 x .4	0.056	0.146	3	1 5/8	1/8	HA	GFS23706.5000
	#2	2-56	2-64	1-64	–	–	2-56	2-64	2.5 x .45	2.5 x .45	0.064	0.172	3	1 5/8	1/8	HA	GFS23706.5001
	#4	4-40	4-48	2-56	–	–	4-40	4-48	–	–	0.081	0.224	3	1 5/8	1/8	HA	GFS23706.5003
	STI 4	–	–	4-40	4-48	–	–	–	–	–	0.117	0.295	3	1 5/8	1/8	HA	GFS23706.5611
	#5	5-40	5-44	–	–	–	5-40	5-44	3 x .5	3 x .5	0.095	0.250	3	1 5/8	1/8	HA	GFS23706.5004
	#6	6-32	6-40	–	–	–	6-32	6-40	–	–	0.100	0.276	3	1 5/8	1/8	HA	GFS23706.5005
	STI 6	–	–	6-32	6-40	–	–	–	5 x .8	5 x .8	0.143	0.364	3	2 1/2	1/4	HB	GFS23106.5613
	#8	8-32	8-36	–	–	–	8-32	8-36	4 x .7	4 x .7	0.124	0.328	3	1 5/8	1/8	HA	GFS23706.5006
STI 8	–	–	8-32	8-36	1/4-32	–	–	–	–	0.167	0.415	3	2 1/2	1/4	HB	GFS23106.5614	
STANDARD SIZES	#10	10-24	10-32	10-24	10-32	–	10-24	10-32	–	–	0.136	0.380	3	2 1/2	1/4	HB	GFS23106.5007
	1/4	1/4-20	1/4-28	1/4-20	1/4-28	5/16-32	1/4-20	1/4-28	6 x 1	6 x 1	0.185	0.500	3	2 1/2	1/4	HB	GFS23106.5009
	5/16	5/16-18	5/16-24	5/16-18	5/16-24	3/8-32	5/16-18	5/16-24	8 x 1.25	8 x 1.25	0.242	0.625	4	2 1/2	1/4	HB	GFS33106.5010 ♠
	3/8	3/8-16	3/8-24	3/8-16	3/8-24	7/16-28	3/8-16	3/8-24	10 x 1.5	10 x 1.5	0.301	0.750	5	2 1/2	5/16	HB	GFS33106.5011 ♠
	7/16	7/16-14	7/16-20	7/16-14	7/16-20	1/2-28	7/16-14	7/16-20	12 x 1.75	12 x 1.75	0.354	0.875	5	3	3/8	HB	GFS33106.5012 ♠
	1/2	1/2-13	1/2-20	1/2-13	1/2-20	5/8-24	1/2-13	1/2-20	14 x 2	14 x 2	0.407	1.00	5	3 3/4	1/2	HB	GFS33106.5013 ♠
	5/8	5/8-11	5/8-18	5/8-11	5/8-18	3/4-20	5/8-11	5/8-18	16 x 2	16 x 2	0.512	1.25	5	3 3/4	1/2	HB	GFS33106.5015 ♠
3/4	3/4-10	3/4-16	3/4-10	3/4-16	7/8-20	3/4-10	3/4-16	20 x 2.5	20 x 2.5	0.630	1.50	6	4 1/4	5/8	HB	GFS33106.5016 ♠	

♠ With internal coolant. Shank Types: HA-Straight shank without clamping flat, HB-Straight shank with Weldon clamping flat

THREADS-ALL / MINIATURE AND STANDARD 3XD THREAD MILLS



BOTH 2XD AND 3XD THREADS-ALL™ TOOLS PROVIDE:

- Easy machining of difficult materials
- One tool for through and blind holes
- Pitch diameter can be easily controlled
- Full bottom threading to within 1 pitch
- STI threads can be easily produced
- Produces excellent thread finish and gaging

3 x D - TICN COATED

	Tool Size	Thread Size					Cutter Dia. (in)	Cut Length (in)	# Flutes	OAL (in)	Shank Dia. (in)	Shank Type	EDP No.
		UNC	UNF	STI UNC	STI UNF	M							
MINIATURE SIZES	#2	2-56	2-64	2-56	2-64	M 2.2	0.067	0.258	3	1.625	1/8	HA	GFS83706.5001
	#4	4-40	4-48	4-40	4-48	M 3	0.085	0.336	3	1.625	1/8	HA	GFS83706.5003
	#6	6-32	6-40	6-32	6-40	M 3.5	0.106	0.414	3	1.625	1/8	HA	GFS83706.5005
	#8	8-32	8-36	8-32	8-36	-	0.132	0.492	3	1.750	3/16	HA	GFS83706.5006
STANDARD SIZES	#10	10-24	-	10-24	-	M 5	0.146	0.570	3	1.875	3/16	HA	GFS83706.5007
		-	10-32	-	10-32	-	0.154	0.570	4	1.875	3/16	HA	GFS83706.5041
	1/4	1/4-20	-	1/4-20	-	M 6	0.195	0.750	4	2.375	1/4	HB	GFS83106.5009
		-	1/4-28	-	1/4-28	-	0.207	0.750	4	2.375	1/4	HB	GFS83106.5043
	5/16	5/16-18	-	5/16-18	-	M 8	0.248	0.937	4	2.563	5/16	HB	GFS83106.5010 ♣
		-	5/16-24	-	5/16-24	-	0.260	0.937	5	2.563	5/16	HB	GFS83106.5044 ♣
	3/8	3/8-16	-	3/8-16	-	M 10	0.303	1.125	5	2.750	5/16	HB	GFS83106.5011 ♣
		-	3/8-24	-	3/8-24	-	0.354	1.125	5	2.875	3/8	HB	GFS83106.5045 ♣
	7/16	7/16-14	-	7/16-14	-	M 12	0.354	1.312	5	3.125	3/8	HB	GFS83106.5012 ♣
		-	7/16-20	-	7/16-20	-	0.376	1.312	5	3.060	3/8	HB	GFS83106.5046 ♣
	1/2	1/2-13	1/2-20	1/2-13	1/2-20	-	0.409	1.500	5	3.625	1/2	HB	GFS83106.5013 ♣
	5/8	5/8-11	5/8-18	5/8-11	5/8-18	M 16	0.514	1.875	5	4.125	5/8	HB	GFS83106.5015 ♣
3/4	3/4-10	3/4-16	3/4-10	3/4-16	-	0.630	2.250	6	4.500	5/8	HB	GFS83106.5016 ♣	

♣ With internal coolant. Shank Types: HA-Straight shank without clamping flat, HB-Straight shank with Weldon clamping flat

THREADS-ALL™ / AERO

For Aerospace and Exotic Materials

The EMUGE THREADS-ALL / AERO line of premium sub-micro grain solid carbide thread mills is ideal in demanding materials and industries such as aerospace where nickel alloys, titanium and stainless steel are the norm. A unique design enables three tooth pitches to simultaneously rough and finish-cut threads, **dramatically increasing tool life and reducing cycle times.**

- Left-hand helix flute design with left-hand spindle rotation greatly enhances stability and performance
- First tooth acts as a rougher, while the second and third teeth finish full thread profile
- **10X higher tool life and cycle time reductions than conventional tools!**
- TIALN-T46 coating resists heat and wear, extending tool life
- One tool easily makes STI threads for both through and blind holes
- Internal coolant tools starting at 1/4" size

Cutting Data on page 41.



2 x D - UNC / UNF

Thread Size		Cutter Dia. (in)	Cut Length (in)	OAL (in)	Shank Dia. (mm)	# Flutes	EDP No.
UNC	UNF						
#2 - 56		0.067	0.181	1.535	3	3	GF26A729.5001
#4 - 40		0.085	0.234	1.535	3	3	GF26A729.5003
#6 - 32		0.106	0.287	1.535	3	3	GF26A729.5005
#10 - 24		0.146	0.398	1.653	4	3	GF26A729.5007
	#10-32	0.154	0.392	1.653	4	4	GF26A729.5041
1/4 - 20		0.195	0.520	2.165	6	3	GF26A729.5009 ♣
	1/4-28	0.207	0.516	2.165	6	5	GF26A729.5043 ♣
5/16 - 18		0.248	0.648	2.283	8	4	GF26A729.5010 ♣
	5/16 - 24 & 3/8 - 24	0.260	0.642	2.283	8	5	GF26A729.5044 ♣
3/8 - 16		0.303	0.656	2.440	8	4	GF26A729.5011 ♣
	7/16 - 20 & 1/2 - 20	0.376	0.896	2.913	10	6	GF26A729.5046 ♣

♣ With internal coolant

NEW 3 x D - UNC / UNF

Thread Size		Cutter Dia. (in)	Cut Length (in)	OAL (in)	Shank Dia. (mm)	# Flutes	EDP No.
UNC	UNF						
#4 - 40		0.085	0.350	1.614	3	3	GF2BA729.5003
#6 - 32		0.106	0.429	1.693	3	3	GF2BA729.5005
#10 - 24		0.146	0.590	1.890	4	3	GF2BA729.5007
	#10 - 32	0.154	0.587	1.811	4	4	GF2BA729.5041
1/4 - 20		0.195	0.776	2.402	6	3	GF2BA729.5009 ♣
	1/4-28	0.207	0.768	2.362	6	5	GF2BA729.5043 ♣
5/16 - 18		0.248	0.965	2.638	8	4	GF2BA729.5010 ♣
	5/16 - 24 & 3/8 - 24	0.260	0.960	2.598	8	5	GF2BA729.5044 ♣
3/8 - 16		0.303	1.157	2.795	8	4	GF2BA729.5011 ♣
	7/16 - 20 & 1/2 - 20	0.376	1.339	3.110	10	6	GF2BA729.5046 ♣

♣ With internal coolant

THREADS-ALL / AERO SOLID CARBIDE THREAD MILLS



2 x D - METRIC / METRIC FINE

Thread Size	Cutter Dia. (mm)	Cut Length (mm)	OAL (mm)	Shank Dia. (mm)	# Flutes	EDP No.
M 3 x 0.5	2.40	6.20	39	3	4	GF26A729.0030
M 3.5 x 0.6	2.78	7.30	39	3	4	GF26A729.0035
M 4 x 0.7	3.15	8.30	42	4	4	GF26A729.0040
M 5 x 0.8	4.04	10.30	52	6	4	GF26A729.0050 ♣
M 6 x 1.0	4.80	12.43	55	6	4	GF26A729.0060 ♣
M 8 x 1.25	6.50	16.70	60	8	4	GF26A729.0080 ♣
M 10 x 1.5	8.20	20.70	70	10	5	GF26A729.0100 ♣
M 12 x 1.75	9.90	24.90	74	10	5	GF26A729.0112 ♣
M 14 x 2.0	11.60	29.00	80	12	5	GF26A729.0114 ♣
M 16 x 2.0	13.60	33.00	85	14	6	GF26A729.0116 ♣

♣ With internal coolant

3 x D - METRIC / METRIC FINE

Thread Size	Cutter Dia. (mm)	Cut Length (mm)	OAL (mm)	Shank Dia. (mm)	# Flutes	EDP No.
M 3 x 0.5	2.40	9.30	41	3	4	GF2BA729.0030
M 4 x 0.7	3.15	12.4	44	4	4	GF2BA729.0040
M 5 x 0.8	4.04	15.4	57	6	4	GF2BA729.0050 ♣
M 6 x 1.0	4.80	18.5	60	6	4	GF2BA729.0060 ♣
M 8 x 1.25	6.50	24.6	67	8	4	GF2BA729.0080 ♣
M 10 x 1.5	8.20	30.8	78	10	5	GF2BA729.0100 ♣
M 12 x 1.75	9.90	36.9	83	10	5	GF2BA729.0112 ♣
M 14 x 2.0	11.6	43.0	95	12	5	GF2BA729.0114 ♣
M 16 x 2.0	13.6	49.0	101	14	6	GF2BA729.0116 ♣

♣ With internal coolant

THREADS-ALL™ / AERO SELF-LOCK

An Integrated Thread Locking System

In an ideal screw connection for high-stress situations, EMUGE SELF-LOCK internal threads yield a self-locking screw connection that can be used repeatedly.

- Self-Lock is a unique thread form that locks a mating bolt into place
- Eliminates the need for secondary adhesives
- Metric Self-Lock threading tools are also available.

2 x D SELF-LOCK - LK-UNC / LK-UNF - TIALN-T46 COATING

Size	Thread	Cutting Dia. (in)	OAL (in)	Shank dia. (mm)	# Flutes	EDP No.
2-56	LK-UNC	0.067	1.535	3	4	GF26A729.5654
4-40		0.085	1.535	3	4	GF26A729.5656
6-32		0.106	1.535	3	4	GF26A729.5658
8-32		0.132	1.654	4	4	GF26A729.5659
10-24		0.146	1.654	4	4	GF26A729.5660
1/4-20		0.195	2.165	6	4	GF26A729.5662 ♣
5/16-18		0.248	2.283	8	5	GF26A729.5663 ♣
3/8-16		0.303	2.441	8	5	GF26A729.5664 ♣
7/16-14		0.354	2.913	10	5	GF26A729.5665 ♣
1/2-13		0.409	3.150	12	5	GF26A729.5666 ♣
10-32	LK-UNF	0.154	1.654	4	5	GF26A729.5711 ♣
1/4-28		0.207	2.165	6	6	GF26A729.5713 ♣
5/16-24		0.260	2.283	8	6	GF26A729.5714 ♣
3/8-24		0.323	2.667	10	7	GF26A729.5715 ♣
7/16-20		0.376	2.913	10	7	GF26A729.5716 ♣
1/2-20		0.437	3.150	12	9	GF26A729.5717 ♣

♣ With internal coolant

EMUGE Thread Plug Gages also available for all Self-Lock thread forms. Visit emuge.com for more info.

Cutting Data on page 41.

NEW

THREADS-ALL™ / MAX

For High Tensile Strength Materials

The EMUGE THREADS-ALL / MAX line of premium sub-micro grain solid carbide thread mills is designed for maximum performance in high tensile strength and hardened materials from 44 to 66 HRC.

The unique geometry and coating combination allows the user to reduce the amount of cutter compensation with less wear per tooth. These tools require less operator intervention than traditional style thread mills.

- THREADS-ALL / MAX has a straight flute, neutral to negative helix for easier penetration in hard metals
- Designed with 4 rows of cutting teeth for maximum stability
- **10X higher tool life and cycle time reductions than conventional tools!**
- TIALN-T46 coating resists heat and wear, extending tool life
- Left-hand cutting edge for left-hand spindle rotation
- Internal coolant options starting at 1/4" / M5

Cutting Data on page 41.



THREADS-ALL / MAX SOLID CARBIDE THREAD MILLS

2 x D - UNC

Thread Size	Cutter dia. (in)	Cut length (in)	OAL (in)	Shank dia. (mm)	# Flutes	EDP No.
#2-56	0.067	0.197	1.535	3	3	GF283729.5001
#4-40	0.085	0.260	1.535	3	3	GF283729.5003
#6-32	0.106	0.323	1.535	3	3	GF283729.5005
#8-32	0.126	0.374	1.654	4	3	GF283729.5006
#10-24	0.146	0.441	1.654	4	3	GF283729.5007
1/4-20	0.195	0.575	2.165	6	3	GF283729.5009 ♣
5/16-18	0.248	0.709	2.283	8	4	GF283729.5010 ♣
3/8-16	0.301	0.843	2.441	8	4	GF283729.5011 ♣
7/16-14	0.354	0.980	2.756	10	4	GF283729.5012 ♣
1/2-13	0.409	1.114	3.150	12	4	GF283729.5013 ♣
9/16-12	0.465	1.252	3.228	12	4	GF283729.5014 ♣
5/8-11	0.512	1.386	3.415	14	5	GF283729.5015 ♣
3/4-10	0.626	1.646	3.740	16	5	GF283729.5016 ♣

♣ With internal coolant

2 x D - UNF

Thread Size	Cutter dia. (in)	Cut length (in)	OAL (in)	Shank dia. (mm)	# Flutes	EDP No.
#10-32	0.154	0.425	1.654	4	4	GF283729.5041
1/4-28	0.207	0.555	2.165	6	5	GF283729.5043 ♣
5/16-24	0.260	0.689	2.230	8	5	GF283729.5044 ♣
3/8-24	0.311	0.811	2.362	8	6	GF283729.5045 ♣
7/16-20	0.360	0.949	2.756	10	6	GF283729.5046 ♣
1/2-20	0.437	1.075	3.071	12	7	GF283729.5047 ♣
9/16-18	0.492	1.209	3.228	14	7	GF283729.5048 ♣
5/8-18	0.547	1.335	3.346	14	8	GF283729.5049 ♣
3/4-16	0.669	1.594	3.740	18	8	GF283729.5050 ♣

♣ With internal coolant

2 x D - METRIC

Thread Size	Cutter dia. (mm)	Cut length (mm)	OAL (mm)	Shank dia. (mm)	# Flutes	EDP No.
M 3 x 0.5	2.40	6.25	51	6	4	GF283729.0030
M 4 x 0.7	3.15	8.35	51	6	4	GF283729.0040
M 5 x 0.8	4.04	10.40	52	6	4	GF283729.0050 ♣
M 6 x 1	4.80	12.30	55	6	4	GF283729.0060 ♣
M 8 x 1.25	6.50	16.60	60	8	4	GF283729.0080 ♣
M 10 x 1.5	8.20	20.75	70	10	5	GF283729.0100 ♣
M 12 x 1.75	9.90	24.85	74	10	5	GF283729.0112 ♣
M 14 x 2	11.60	29.00	85	12	5	GF283729.0114 ♣
M 16 x 2	13.60	33.00	90	14	5	GF283729.0116 ♣
M 20 x 2.5	17.00	41.25	102	18	6	GF283729.0120 ♣

♣ With internal coolant



NEW

THREADS-ALL™ / HEADED

Exchangeable Face Insert Thread Milling System for Making Larger Threads

Circular thread milling bar / bodies with exchangeable face inserts provide an excellent modular solution for milling larger thread dimensions. Face inserts incorporate the THREADS-ALL program tooth design / geometry, for maximum tool life and performance.

- Rigid, anti-vibration body design allows for a length-to-diameter ratio to 2 x D and greater
- PVD coated insert application range
- Micro-grain carbide face inserts with ALCR-42 coating are ideal for stainless steels, titanium, nickel alloys, cast iron, hard high alloy steel > 25 HRC, mold and tool steels
- Low radial cutting pressure ensures true-to-gage threads
- Fast and easy setup, programming and maintenance
- Innovative internal coolant supply exits radially at the insert cutting edge for optimized cooling, chip evacuation and thread quality
- Face inserts are rigidly affixed in a solid steel precision pocket, securely fastened with a Torx locking screw



TOOL BODIES - WITH COOLANT-THRU

Bar Size letter must match corresponding insert size letter (see page 13 for inserts)

Bar Size	Cutter Dia. (mm)	Min. Thread Dia.	Max Depth (mm)	Shank Dia. (mm)	OAL (mm)	EDP No.
A	9.9	1/2"-M12	24	10	68	GZ38100A
			30	10	74	GZ38110A
			36	10	80	GZ38120A
B	11.6 & 11.9	9/16"-M14	28	10	71.5	GZ38100B
			35	10	78.5	GZ38110B
			42	10	85.5	GZ38120B
G	13.6 & 13.9	* 5/8"- M16	32	12	80.5	GZ38100G
			40	12	88.5	GZ38110G
			48	12	96.5	GZ38120G
C	15.9	3/4"- M20	40	14	88	GZ38100C
			50	14	98	GZ38110C
			60	14	108	GZ38120C
D	19.9	1" - M24	48	16	99	GZ38100D
			60	16	111	GZ38110D
			72	16	123	GZ38120D
E	24.9	1 1/2" - M30	60	20	115	GZ38100E
			75	20	130	GZ38110E
			90	20	145	GZ38120E
F	29.9	1 1/2" - M36	72	25	133	GZ38100F
			90	25	151	GZ38110F
			108	25	169	GZ38120F

Cutting Data on page 41.

THREADS-ALL / HEADED EXCHANGEABLE FACE INSERT THREAD MILLING



INSERTS - UNC/UNF & METRIC / METRIC FINE

Insert Size	Cutter Dia. (mm)	Min. Thread dia.	Thread Pitch Range		# Flutes	EDP No.
			Inch (TPI)	Metric		
A	9.9	1/2"-M12	24-13	1.0-1.75	6	GF65310A.9512
		M14	14-12	1.75-2.0	6	GF65310A.0114
B	11.6	9/16"-M14	24-12	1.0-2.0	7	GF65320A.9512
	11.9	M16	12-10	2.0-2.5	7	GF65320A.0118
G	13.6	* 5/8"-M16	24-12	1.0-2.0	8	GF65370A.9512
	13.9	M18	12-10	2.0-2.5	8	GF65370A.0118
C	15.9	3/4"-M20	16-10	1.5-2.5	8	GF65330A.9514
		7/8"-M24	10-8	2.5-3.0	8	GF65330A.0124
D	19.9	1"-M24	16-8	1.5-3.0	8	GF65340A.9514
		1 1/8"-M30	8-7	3.0-3.5	8	GF65340A.0130
E	24.9	1 1/4"-M30	12-7	2.0-3.5	9	GF65350A.9516
		1 1/2"-M36	7-6	3.5-4.0	9	GF65350A.0136
F	29.9	1 1/2"-M36	8-6	3.0-4.0	10	GF65360A.9518

* For 5/8-11 Threads we recommend a minor diameter range at 0.539" min to 0.546" max.

INSERTS - NPT THREADS

Insert Size	Cutter Dia. (mm)	NPT Thread Size (in)	Pitch (TPI)	# Flutes	EDP No.
A	9.9	1/4 & 3/8	18	5	GF65310A.9677
C	15.9	1/2 & 3/4	14	5	GF65330A.9678
E	24.9	1-2	11 1/2	6	GF65350A.9679
F	29.9	2 1/2-8	8	9	GF65360A.9680

INSERTS - G THREADS (BSP) BSW, BSF, W

Insert Size	Cutter Dia. (mm)	G Thread Size	Pitch (TPI)	# Flutes	EDP No.
A	9.9	G 1/4	19-32	6	GF65310A.9545
B	11.9	G 3/8	16-26	7	GF65320A.9545
G	13.9	G 3/8	16-36	8	GF65370A.9545
C	15.9	G 1/2, G 5/8	14-20	8	GF65330A.9548
D	19.9	≥ G 3/4	10-14	8	GF65340A.9550
E	24.9	≥ G 7/8	8-14	9	GF65350A.9550
F	29.9	≥ G 1 1/8	7-11	10	GF65360A.9550



INSERTS - OD (EXTERNAL) - UNC / UNF & METRIC / METRIC FINE

Insert Size	Cutter Dia. (mm)	Min. Thread dia. (mm)	Thread Pitch Range		# Flutes	EDP No.
			Inch (TPI)	Metric		
C	15.9	6	24	1.0-1.75	8	GF65130A.9512
		8	20	1.75-2.0	8	GF65130A.9513
		10	18-16	1.0-2.0	8	GF65130A.9514
		12	14	2.0-2.5	8	GF65130A.9515
		14	12	1.0-2.0	8	GF65130A.9516
		18	11-10	2.0-2.5	8	GF65130A.9517

THRILLER

Drill, Thread Mill and Chamfer a hole with a single tool

EMUGE led the industry with the introduction of the first thread mill that could drill, thread mill and chamfer a hole with a single tool and it was called the THRILLER. The original THRILLER design is useful in short chip forming materials such as cast iron or high silicon aluminum.

The THRILLER is now a family of products that have the ability to drill a hole as well as thread with a single tool and are available in designs that can machine a wide range of materials such as steel, stainless steel and even nickel alloys.

THRILLER thread milling does not require a pre-drilled hole prior to the thread milling operation.

THRILLER thread mills come in **2 PRODUCT TYPES:**

Thriller



Thriller-AERO & Thriller-MAX



Cutting Data on page 42.

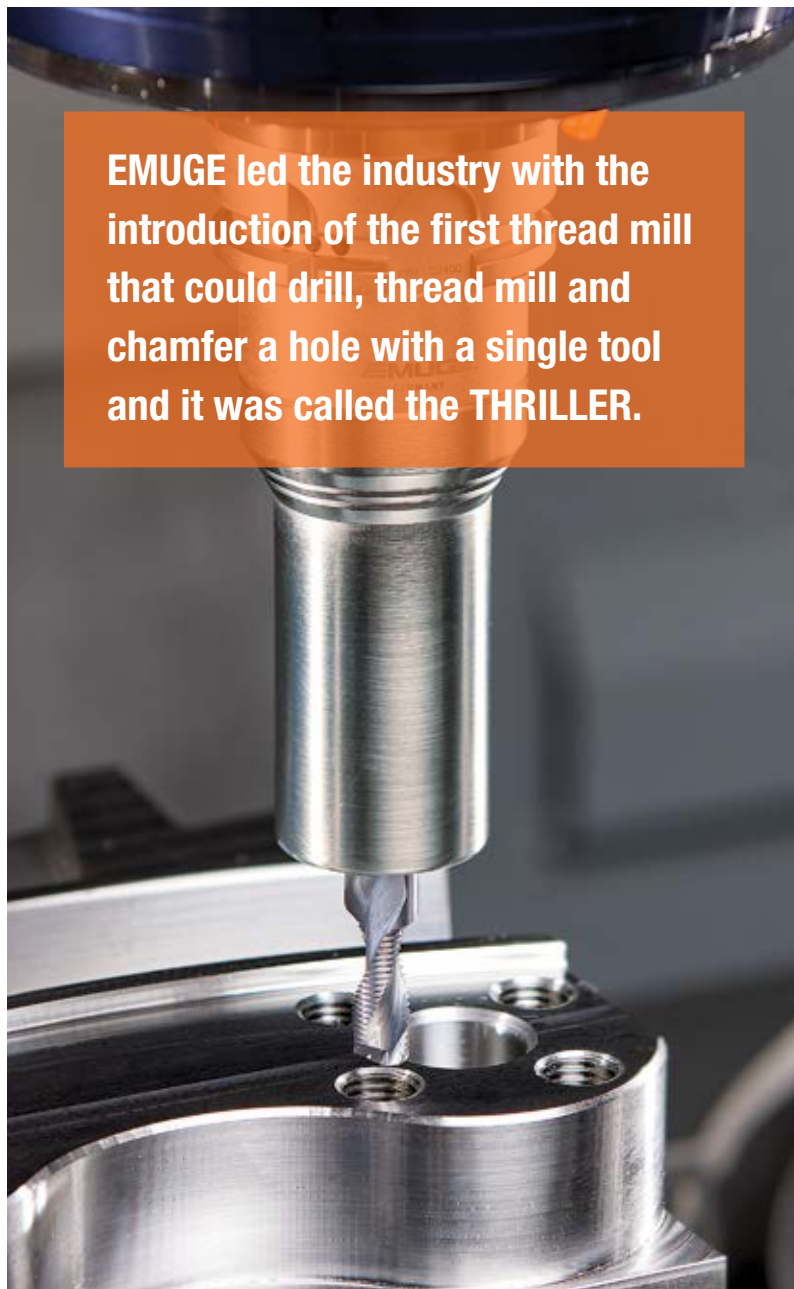

EMUGE led the industry with the introduction of the first thread mill that could drill, thread mill and chamfer a hole with a single tool and it was called the THRILLER.

THRILLER Drill / Chamfer / Thread Milling Cycle

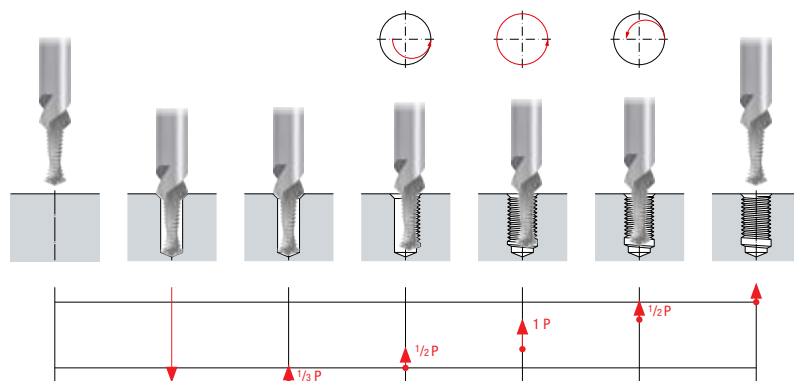

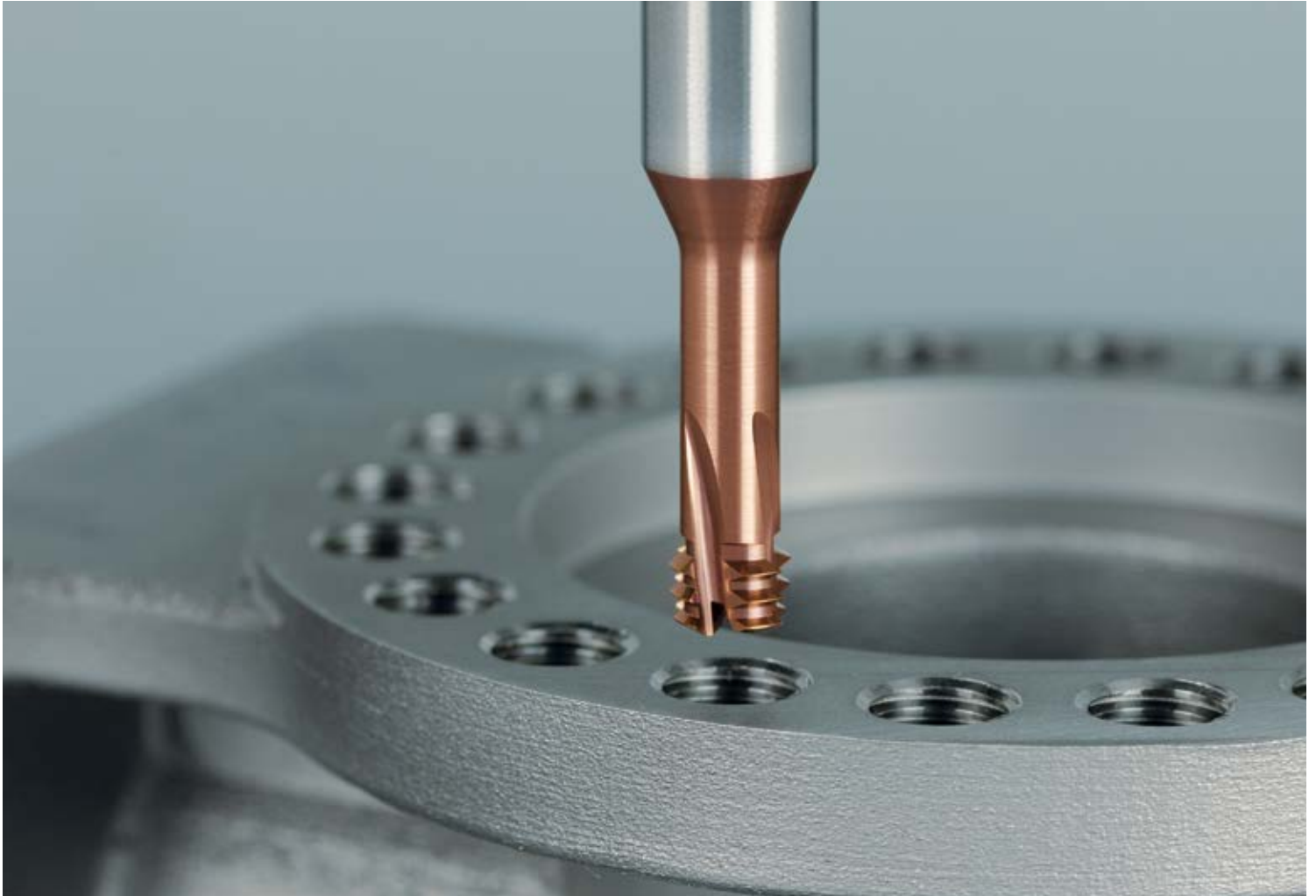

The THRILLER-AERO and THRILLER-MAX thread mills are designed for materials beyond short chipping alloys. These tools use a different helical interpolation strategy than a traditional drill point THRILLER to produce the final threaded hole.

THRILLER-AERO and THRILLER-MAX Drill / Thread Milling Cycle

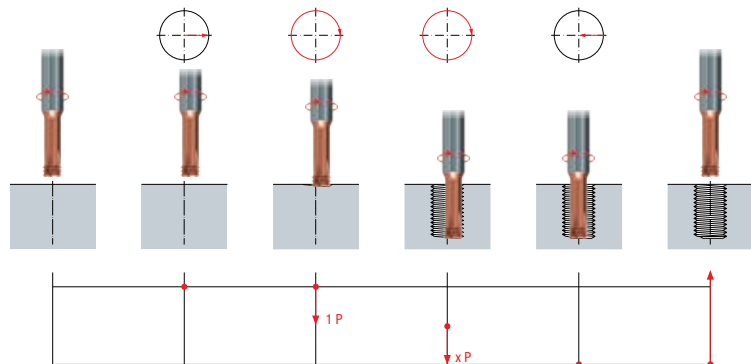

THRILLER

Combined Drill, Chamfer and Thread Milling Tool

The THRILLER combines three operations in one tool and is designed specifically for short chip forming materials. In addition to the 2 x D offering shown, EMUGE offers 2- and 3-flute stocked standard designs, as well as 1.5 x D and 2.5 x D lengths. Visit emuge.com for more information.

- Premium sub-micro grain solid carbide substrate
- 140° drill point angle
- 90° chamfer angle
- 2 x D length of cut
- Additional tool design options available at emuge.com
- Bright finish or TiCN coated for cast materials
- Helical flute design for chip evacuation
- Best suited for short-chipping cast aluminum alloys and cast iron

Cutting Data on page 42.

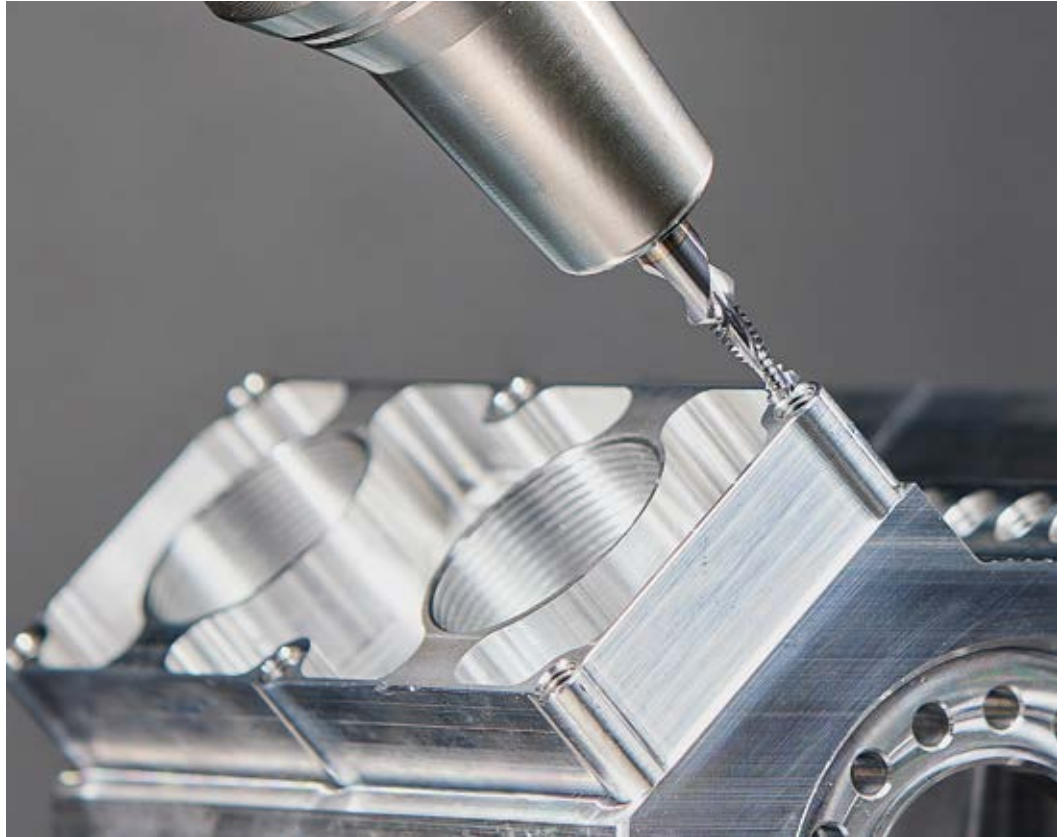

2 x D - UNC - COARSE THREAD - WITH COOLANT-THRU

Thread Size	OAL (in)	Thread Depth (in)	Chamfer Depth (in)	Cutter Dia. (in)	Shank Dia. (in)	Bright Finish EDP No.	TiCN Coated EDP No.
1/4-20	2.441	0.504	0.622	0.191	0.315	GF432201.5009	GF432206.5009
5/16-18	2.913	0.615	0.752	0.246	0.394	GF432201.5010	GF432206.5010
3/8-16	3.110	0.754	0.913	0.301	0.472	GF432201.5011	GF432206.5011
7/16-14	3.110	0.862	1.043	0.354	0.472	GF432201.5012	GF432206.5012
1/2-13	3.504	1.005	1.205	0.407	0.551	GF432201.5013	GF432206.5013
9/16-12	4.016	1.089	1.307	0.465	0.630	GF432201.5014	GF432206.5014
5/8-11	4.016	1.187	1.425	0.516	0.709	GF432201.5015	GF432206.5015

2 x D - UNF - FINE THREAD - WITH COOLANT-THRU

Thread Size	OAL (in)	Thread Depth (in)	Chamfer Depth (in)	Cutter Dia. (in)	Shank Dia. (in)	Bright Finish EDP No.	TiCN Coated EDP No.
1/4-28	2.441	0.504	0.602	0.207	0.315	GF432201.5043	GF432206.5043
5/16-24	2.913	0.629	0.748	0.260	0.394	GF432201.5044	GF432206.5044
3/8-24	3.110	0.754	0.882	0.323	0.472	GF432201.5045	GF432206.5045
7/16-20	3.110	0.855	1.004	0.376	0.472	GF432201.5046	GF432206.5046
1/2-20	3.504	1.006	1.169	0.437	0.551	GF432201.5047	GF432206.5047
9/16-18	4.016	1.117	1.299	0.492	0.630	GF432201.5048	GF432206.5048
5/8-18	4.016	1.229	1.421	0.555	0.709	GF432201.5049	GF432206.5049

2 x D - METRIC - COARSE THREAD - 2 FLUTES - WITH COOLANT-THRU

Thread Size	OAL (mm)	Thread Depth (mm)	Chamfer Depth (mm)	Cutter Dia. (mm)	Shank Dia. (mm)	Bright Finish EDP No.	TICN Coated EDP No.
M 4 x 0.7	49	7.74	9.5	3.16	6	GF432201.0040	GF432206.0040
M 5 x 0.8	55	9.65	11.8	4.04	6	GF432201.0050	GF432206.0050
M 6 x 1	62	12.06	14.6	4.8	8	GF432201.0060	GF432206.0060
M 8 x 1.25	74	15.08	18.3	6.5	10	GF432201.0080	GF432206.0080
M 10 x 1.5	79	19.59	23.6	8.2	12	GF432201.0100	GF432206.0100
M 12 x 1.75	89	22.86	27.5	9.9	14	GF432201.0112	GF432206.0112
M 14 x 2	102	28.12	33.5	11.6	16	GF432201.0114	GF432206.0114
M 16 x 2	102	32.13	37.9	13.6	18	GF432201.0116	GF432206.0116

2 x D - METRIC - COARSE THREAD - 3 FLUTES - WITH COOLANT-THRU

Thread Size	OAL (mm)	Thread Depth (mm)	Chamfer Depth (mm)	Cutter Dia. (mm)	Shank Dia. (mm)	Bright Finish EDP No.	TICN Coated EDP No.
M 6 x 1	62	12.06	14.6	4.8	8	GF432251.0060	GF432256.0060
M 8 x 1.25	74	15.08	18.3	6.5	10	GF432251.0080	GF432256.0080
M 10 x 1.5	79	19.59	23.6	8.2	12	GF432251.0100	GF432256.0100
M 12 x 1.75	89	22.86	27.5	9.9	14	GF432251.0112	GF432256.0112
M 16 x 2	102	32.13	37.9	13.6	18	GF432251.0116	GF432256.0116

2 x D - METRIC - FINE THREAD - WITH COOLANT-THRU

Thread Size	OAL (mm)	Thread Depth (mm)	Chamfer Depth (mm)	Cutter Dia. (mm)	Shank Dia. (mm)	Bright Finish EDP No.	TICN Coated EDP No.
M 6 x 0.75	62	12.07	14.3	5.05	8	GF432201.0229	GF432206.0229
M 8 x 1	74	16.09	19	6.75	10	GF432201.0251	GF432206.0251
M 10 x 1	79	20.11	23.4	8.7	12	GF432201.0276	GF432206.0276
M 10 x 1.25	79	20.11	23.8	8.4	12	GF432201.0277	GF432206.0277
M 12 x 1.25	89	23.88	27.9	10.4	14	GF432201.0302	GF432206.0302
M 12 x 1.5	89	24.12	28.5	10.15	14	GF432201.0303	GF432206.0303
M 14 x 1.5	102	27.14	31.8	12.1	16	GF432201.0331	GF432206.0331
M 16 x 1.5	102	31.65	36.7	14.1	18	GF432201.0359	GF432206.0359

2 x D - STI-METRIC - COARSE THREAD - FOR WIRE THREAD INSERTS - WITH COOLANT-THRU

Thread Size	OAL (mm)	Thread Depth (mm)	Chamfer Depth (mm)	Cutter Dia. (mm)	Shank Dia. (mm)	Bright Finish EDP No.	TICN Coated EDP No.
STI-M 6 x 1	74	13.10	15.9	6	10	GF432201.0971	GF432206.0971
STI-M 8 x 1.25	79	16.35	19.9	8.1	12	GF432201.0973	GF432206.0973
STI-M 10 x 1.5	89	21.13	25.5	10	14	GF432201.0975	GF432206.0975
STI-M 12 x 1.75	102	24.63	29.7	12.1	16	GF432201.0977	GF432206.0977
STI-M 14 x 2	102	30.12	36	14.1	18	GF432201.0978	GF432206.0978
STI-M 16 x 2	115	34.17	40.4	16	20	GF432201.0979	GF432206.0979



THRILLER-AERO

For Aerospace and Nickel Alloy Materials

THRILLER-AERO circular drill / thread mills produce both the core hole and the internal thread in one operation. In addition, the thread hole can be circularly machined with a 120° chamfer. This means that no additional tools are required for drilling and countersinking.

The cutting edge geometry of these left-hand turning tools is designed not only for stainless steel and titanium materials but also for nickel alloys such as Inconel.

Advantage of THRILLER-AERO Thread Mills

- Geometry with additional face cutting
- Thread can be circularly machined with a 120° chamfer as shown on the cycle diagram below
- No burr formation in transition from thread profile to drilled hole
- 2 x D thread depth
- HA cylindrical shank design
- ALCR-89 coating for heat and wear resistance
- Axial coolant-fed for enhanced chip evacuation
- Left-hand helix with left-hand spindle rotation helps improve stability and performance
- 3-tooth design where the first tooth acts as a rougher and the 2nd and 3rd teeth finish the thread profile
- The profile increases tool life while reducing cycle times

Cutting Data on page 42.



THRILLER-AERO Circular Chamfering Cycle

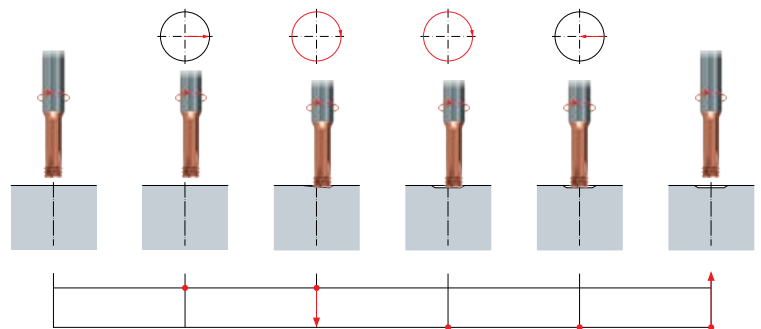



2 x D - UNC

Thread Size	Cutter Dia. (in)	OAL (in)	Cut Length (in)	Shank Dia. (mm)	Clamping Length (mm)	# Flutes	EDP No.
#6-32	0.096	1.535	0.323	3	28	3	GF7B682B.5005
#8-32	0.122	1.575	0.374	4	28	3	GF7B682B.5006
#10-24	0.133	1.654	0.441	4	28	3	GF7B682B.5007
1/4-20	0.180	2.165	0.575	6	36	3	GF7B682B.5009 ♣
5/16-18	0.232	2.283	0.709	8	36	4	GF7B682B.5010 ♣
3/8-16	0.284	2.441	0.843	8	36	4	GF7B682B.5011 ♣
7/16-14	0.334	2.756	0.980	10	40	4	GF7B682B.5012 ♣
1/2-13	0.387	3.150	1.114	12	45	4	GF7B682B.5013 ♣

♣ With internal coolant

2 x D - UNF

Thread Size	Cutter Dia. (in)	OAL (in)	Cut Length (in)	Shank Dia. (mm)	Clamping Length (mm)	# Flutes	EDP No.
#10-32	0.146	1.654	0.425	4	28	4	GF7B682B.5041
1/4-28	0.199	2.165	0.555	6	36	5	GF7B682B.5043 ♣
5/16-24	0.251	2.283	0.689	8	36	5	GF7B682B.5044 ♣
3/8-24	0.314	2.441	0.811	8	36	6	GF7B682B.5045 ♣
7/16-20	0.365	2.756	0.949	10	40	6	GF7B682B.5046 ♣
1/2-20	0.428	3.150	1.075	12	45	7	GF7B682B.5047 ♣

♣ With internal coolant

2 x D - METRIC

Thread Size	Cutter Dia. (mm)	OAL (mm)	Cut Length (mm)	Shank Dia. (mm)	Clamping Length (mm)	# Flutes	EDP No.
M 3x0.5	2.25	39	6.80	3	28	4	GF7B682B.0030
M 4x0.7	2.95	42	9.10	4	28	4	GF7B682B.0040
M 5x0.8	3.80	52	11.20	6	36	4	GF7B682B.0050 ♣
M 6x1	4.50	55	13.50	6	36	4	GF7B682B.0060 ♣
M 8x1.25	6.125	60	17.90	8	36	4	GF7B682B.0080 ♣
M 10x1.5	7.75	70	22.30	10	40	4	GF7B682B.0100 ♣
M 12x1.75	9.375	74	26.60	10	40	5	GF7B682B.0112 ♣

♣ With internal coolant

NEW

THRILLER-MAX

For High Tensile Strength and Hardened Materials

THRILLER-MAX thread mills are designed to dramatically improve tool life and performance in hard to machine, high tensile strength materials. The unique cutting profile can help reduce the number of passes in the threading cycle without sacrificing tool life in the most challenging applications. Well suited for die and mold industry applications or heat treated steel parts.

Advantages of circular drill thread mills

- For hardened materials 44 to 66 HRC
- 2.5 x D thread depth
- HA cylindrical shank design
- ALCR-89 coating for heat and wear resistance
- Left-hand cutting edge for left-hand spindle rotation
- Four rows of cutting teeth for maximum stability
- The profile increases tool life while reducing cycle time
- All tools size 1/4" / M6 and larger are axial coolant-fed to improve chip evacuation

Cutting Data on page 42.



2.5 x D - UNC

Thread Size	Cutter Dia. (in)	Cut Length (in)	OAL (in)	Shank Dia. (mm)	Clamping Length (mm)	# Flutes	EDP No.
#10-24	0.130	0.539	2.165	6	36	3	GF74370B.5007
1/4-20	0.177	0.701	2.362	6	36	3	GF74370B.5009 ♣
5/16-18	0.232	0.866	2.441	6	36	4	GF74370B.5010 ♣
3/8-16	0.283	1.031	2.677	8	36	4	GF74370B.5011 ♣
7/16-14	0.335	1.201	3.071	10	40	4	GF74370B.5012 ♣
1/2-13	0.390	1.366	3.228	10	40	4	GF74370B.5013 ♣
5/8-11	0.492	1.701	3.858	14	45	4	GF74370B.5015 ♣
3/4-10	0.606	2.024	4.331	16	48	5	GF74370B.5016 ♣

♣ With internal coolant

2.5 x D - UNF

Thread Size	Cutter Dia. (in)	Cut Length (in)	OAL (in)	Shank Dia. (mm)	Clamping Length (mm)	# Flutes	EDP No.
#10-32	0.138	0.524	2.165	6	36	4	GF74370B.5041
1/4-28	0.189	0.677	2.283	6	36	4	GF74370B.5043 ♣
5/16-24	0.244	0.843	2.520	8	36	4	GF74370B.5044 ♣
3/8-24	0.303	1.000	2.588	8	36	4	GF74370B.5045 ♣
7/16-20	0.350	1.169	2.992	10	40	4	GF74370B.5046 ♣
1/2-20	0.413	1.327	3.346	12	45	4	GF74370B.5047 ♣
9/16-18	0.465	1.488	3.543	12	45	4	GF74370B.5048 ♣
5/8-18	0.524	1.646	3.661	14	45	5	GF74370B.5049 ♣
3/4-16	0.626	1.969	4.133	16	48	5	GF74370B.5050 ♣

♣ With internal coolant

2.5 x D - METRIC

Thread Size	Cutter Dia. (mm)	Cut Length (mm)	OAL (mm)	Shank Dia. (mm)	Clamping Length (mm)	# Flutes	EDP No.
M 3 x 0.5	2.30	8.30	51	6	36	4	GF74370B.0030
M 4 x 0.7	3.00	11.10	55	6	36	4	GF74370B.0040
M 5 x 0.8	3.80	13.70	55	6	36	4	GF74370B.0050
M 6 x 1	4.60	16.50	58	6	36	4	GF74370B.0060 ♣
M 8 x 1.25	6.20	21.90	65	8	36	4	GF74370B.0080 ♣
M 10 x 1.5	7.80	27.30	68	8	36	4	GF74370B.0100 ♣
M 12 x 1.75	9.50	32.60	78	10	40	4	GF74370B.0112 ♣
M 14 x 2	11.10	38.00	90	12	45	4	GF74370B.0114 ♣
M 16 x 2	13.10	43.00	95	14	45	5	GF74370B.0116 ♣

♣ With internal coolant

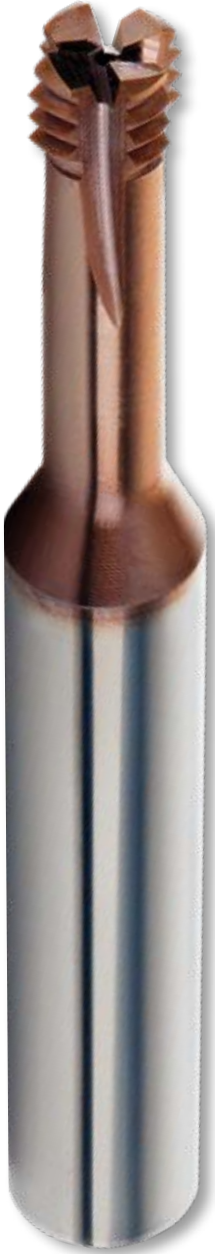

SHUR-THREAD™

Creates One Thread Size and Pitch

The SHUR-THREAD family of tooling are typically full profile thread mills designed to cut one thread size and pitch. The tools are for a specific pitch with corrected thread profile.

Full profile thread mills require a single 360° cutting rotation to complete the full threading operation. The “SHURest” way to easily produce a milled thread is with this style of tool.

All SHUR-THREAD tools require a pre-drilled hole prior to thread milling.

- High process reliability characteristics
- Axial coolant fed options starting at #10 thread size
- Spiral flute for optimized chip evacuation
- TiCN coating for maximum wear resistance
- Well suited for a wide range of materials
- Premium sub-micro grain solid carbide substrate for longer tool life

Cutting Data on page 43.

SHUR-THREAD thread mills are available in 2 PRODUCT STYLES:

Full Profile (UNC/UNF, M/MF)



Full Profile (Pipe Threads)



SHUR-THREAD Milling Cycle

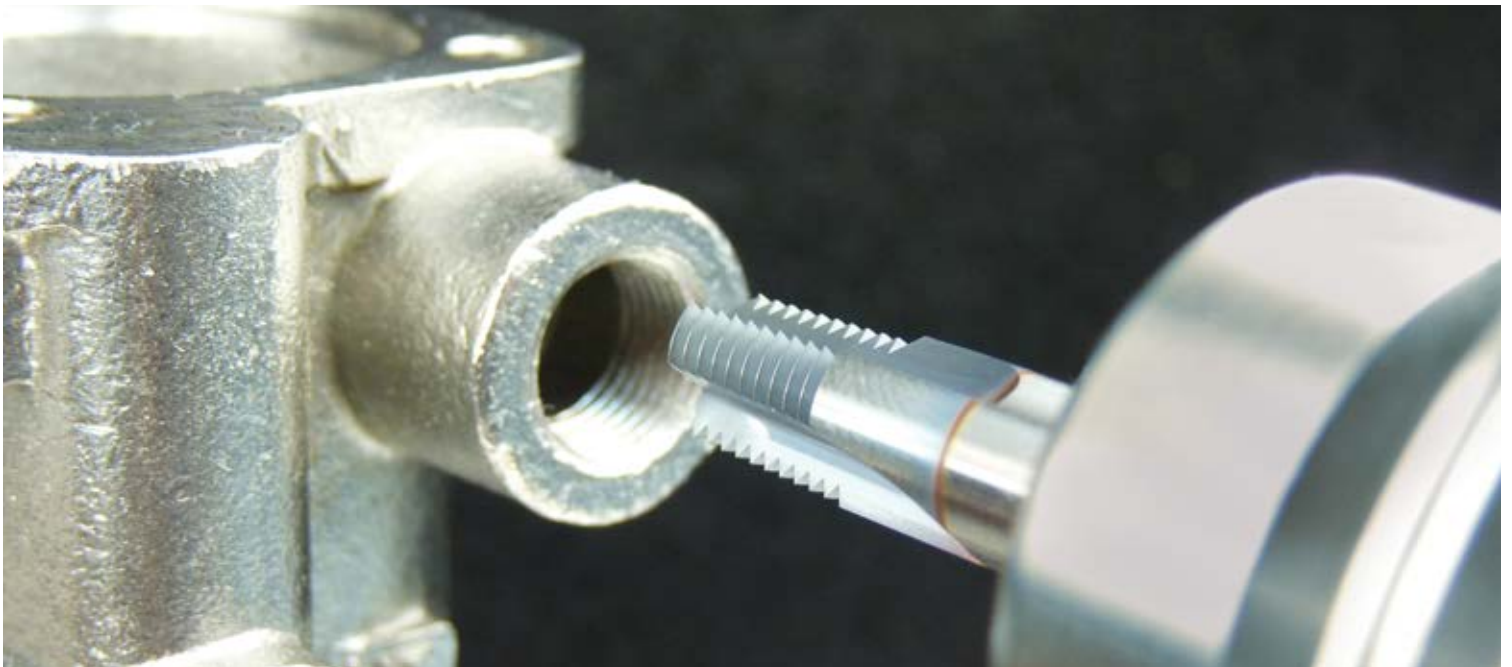
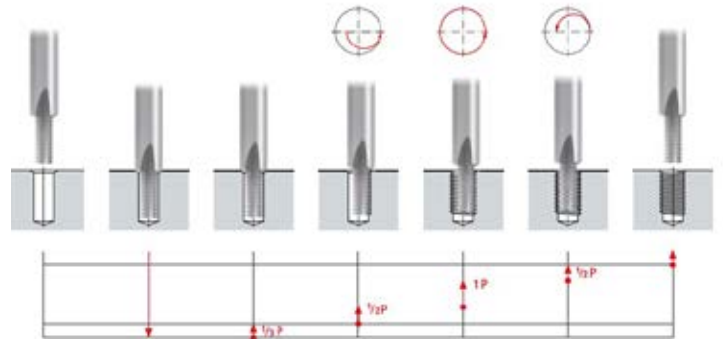



NEW MultiThread Mill, for NPT/NPTF thread milling applications



SHUR-THREAD™

Solid Carbide Thread Mills for 1 1/8" and under, with or without Coolant-Thru

SHUR-THREAD redefines the measure of value in solid carbide thread mills. This tooling line is packed with essential advanced technology for assured quality, performance, versatility, and ease-of-use.

The SHUR-THREAD Series is designed and priced to offer a superior level of value for any size machine shop or production volume. When combined with the latest CNC technology and smart controllers; outstanding flexibility, process control, tool life and part quality can be realized.

- **Premium micro-grain solid carbide** with state-of-the-art grinding techniques
- **Specially engineered** multiple-spiral flutes eliminate chatter
- **Large cutter diameter with high profile correction** ensures true-to-gage threads
- **Extended milling portion** allows for length-of-cut to 2 x D
- **Enlarged flute space** for efficient chip evacuation
- **End mill type shank** with clamping flat for secure tool holding

2 x D - WITHOUT COOLANT-THRU

Thread Size	Cutter Dia. (in)	Cut Length (in)	# Flutes	OAL (in)	Shank Dia. (in)	EDP No.
#10 - 24	0.136	0.395	3	2 1/2	1/4	GFR15106.5007
#10 - 32	0.150	0.390	3	2 1/2	1/4	GFR15106.5041
1/4 - 20	0.185	0.524	3	2 1/2	1/4	GFR15106.5009
1/4 - 28	0.203	0.517	3	2 1/2	1/4	GFR15106.5043
5/16 - 18	0.242	0.637	3	2 1/2	1/4	GFR15106.5010
5/16 - 24	0.246	0.644	3	2 1/2	1/4	GFR15106.5044
3/8 - 16	0.301	0.780	3	2 1/2	5/16	GFR15106.5011
3/8 - 24	0.309	0.769	3	2 1/2	5/16	GFR15106.5045
7/16 - 14	0.354	0.891	3	3	3/8	GFR15106.5012
7/16 - 20	0.371	0.874	3	3	3/8	GFR15106.5046
1/2 - 13	0.371	1.036	3	3	3/8	GFR15106.5013
1/2 - 20	0.371	1.023	3	3	3/8	GFR15106.5047
5/8 - 11	0.496	1.316	4	3 3/4	1/2	GFR15106.5015
3/4 - 10	0.621	1.548	4	4 1/4	5/8	GFR15106.5016
7/8 - 9	0.621	1.829	4	4 1/4	5/8	GFR15106.5017
1" - 8 & 1 1/8 - 8	0.746	2.058	4	4 3/4	3/4	GFR15106.5018

- **TiCN coated** for long tool life
- **Produce threads 1 1/8" and under** in a wide range of soft and pre-hardened steels to 58 HRC, Stainless Steels, Aluminum, Cast Iron, Titanium, Inconel and all difficult to machine exotics



Cutting Data on page 43.

2 x D - WITH COOLANT-THRU

	Thread Size	Cutter Dia. (in)	Cut Length (in)	# Flutes	OAL (in)	Shank Dia. (in)	EDP No.
	#10 - 24	0.136	0.395	3	2 1/2	1/4	GFR35106.5007
	#10 - 32	0.150	0.390	3	2 1/2	1/4	GFR35106.5041
	1/4 - 20	0.185	0.524	3	2 1/2	1/4	GFR35106.5009
	1/4 - 28	0.203	0.517	3	2 1/2	1/4	GFR35106.5043
	5/16 - 18	0.242	0.637	3	2 1/2	1/4	GFR35106.5010
	5/16 - 24	0.246	0.644	3	2 1/2	1/4	GFR35106.5044
	3/8 - 16	0.301	0.780	3	2 1/2	5/16	GFR35106.5011
	3/8 - 24	0.309	0.769	3	2 1/2	5/16	GFR35106.5045
	7/16 - 14	0.354	0.891	3	3	3/8	GFR35106.5012
	7/16 - 20	0.371	0.874	3	3	3/8	GFR35106.5046
	1/2 - 13	0.371	1.036	3	3	3/8	GFR35106.5013
	1/2 - 20	0.371	1.023	3	3	3/8	GFR35106.5047
	9/16 & 5/8-18	0.496	1.138	4	3 3/4	1/2	GFR35106.5048
	5/8 - 11	0.496	1.316	4	3 3/4	1/2	GFR35106.5015
	3/4 - 10	0.621	1.548	4	4 1/4	5/8	GFR35106.5016
	3/4 - 16	0.621	1.530	4	4 1/4	5/8	GFR35106.5050
	7/8 - 9	0.621	1.829	4	4 1/4	5/8	GFR35106.5017
	7/8 -14 & 1"-14	0.621	1.817	4	4 1/4	5/8	GFR35106.5051
	1"- 8 & 1 1/8 - 8	0.746	2.058	4	4 3/4	3/4	GFR35106.5018
METRIC	M 6 x 1.0	0.189	0.491	3	2 1/2	1/4	GFR35106.0060
	M 8 x1.25	0.246	0.663	3	2 1/2	1/4	GFR35106.0080
	M 10 x 1.5	0.309	0.796	3	2 1/2	5/16	GFR35106.0100
	M 12 x 1.75	0.371	0.997	3	3	3/8	GFR35106.0112
	M 14 x 2.0	0.457	1.140	4	3 3/4	1/2	GFR35106.0114
	M 16 x 2.0	0.496	1.280	4	3 3/4	1/2	GFR35106.0116
	M 20 x 2.5	0.621	1.595	4	4 1/4	5/8	GFR35106.0120
	M 24 x 3.0	0.746	1.920	4	4 3/4	3/4	GFR35106.0124

MultiTHREAD MILL

SHUR-THREAD API-LP

- Premium micro-grain solid carbide substrate
- Increased core diameter for maximum rigidity and stability
- Precise cutting geometry ensuring long life and superior threads

MultiTHREAD™ MILL

MultiTHREAD MILL is a full form style for creating NPT /NPTF American Standard Pipe threads that will cut a wide range of materials including carbon steel, steel alloys, stainless steel, aluminum and copper.

- Well suited for the job shop environment
- 15° left-hand spiral flute geometry for blind and through hole applications in most materials
- For the production of internal threads
- Tool for different thread sizes with standard thread profile (but for one pitch only)
- TiCN coated for wear resistance and longer tool life
- HA cylindrical shank - h6 tolerance

SHUR-THREAD™

Universal Applications

Thread mills are designed to produce internal NPT /NPTF pipe threads to a close tolerance on thread dimensions and limits of size, with excellent surface quality on the thread flanks to consistently achieve tight, leak-free joints.

- Advanced SHUR-THREAD thread mills are finished ground with precise geometry to ensure long tool life, low cycle times and superior finished threads in all materials up to 58 HRC
- PVD coated multilayer TiCN for wear resistance
- HB Weldon shank - h6 tolerance

SHUR-THREAD™ API-LP

High Performance Design

High performance thread mills for NPT threads. Extended milling section with 14 teeth, produces API-LP thread depth.

- Innovative left-hand flute geometry / anti-vibration design
- Extended milling section for API-LP thread depth
- TiAlN-T46 multilayer coating resists heat, edge wear and chipping
- Multiple thread sizes are possible with one tool
- Precision ground for repeatability
- Features external coolant channels only
- HB Weldon shank - h6 tolerance

NPT / NPTF / API-LP TAPER PIPE SOLID CARBIDE THREAD MILLS

SHUR-THREAD NPT / NPTF



MULTI-THREAD MILL NPT

Size	Cutter Dia. (in)	Pitch	Flute Length (in)	OAL (in)	# Flutes	Shank Dia. (in)	EDP No.
1/16 - 1/8"	0.232	27	0.536	2.25	4	0.313	GFT9B806.9676
1/4 - 3/8"	0.400	18	0.803	3.25	4	0.500	GFT9B816.9677
1/2 - 3/4"	0.561	14	1.034	3.50	4	0.625	GFT9B836.9678
1 - 2"	0.772	11.5	1.260	3.75	5	0.750	GFT9B856.9679

MULTI-THREAD MILL NPTF

Size	Cutter Dia. (in)	Pitch	Flute Length (in)	OAL (in)	# Flutes	Shank Dia. (in)	EDP No.
1/16 - 1/8"	0.232	27	0.536	2.25	4	0.313	GFT9B806.9681
1/4 - 3/8"	0.400	18	0.803	3.25	4	0.500	GFT9B816.9682
1/2 - 3/4"	0.561	14	1.034	3.50	4	0.625	GFT9B836.9683
1 - 2"	0.772	11.5	1.260	3.75	5	0.750	GFT9B856.9684

SHUR-THREAD NPT

Size	Cutter Dia. (in)	Pitch	Flute Length (in)	OAL (in)	# Flutes	Shank Dia. (in)	EDP No.
1/16	0.232	27	0.39	2.25	3	0.313	GFT53106.5763
1/8	0.301	27	0.39	2.25	3	0.313	GFT53106.5764
1/4	0.400	18	0.58	3.25	3	0.500	GFT53116.5765
3/8	0.439	18	0.58	3.25	4	0.500	GFT53116.5766
1/2 - 3/4	0.561	14	0.75	3.50	4	0.625	GFT53136.9678
1" - 2"	0.772	11.5	0.91	3.75	5	0.750	GFT53156.9679

SHUR-THREAD NPTF

Size	Cutter Dia. (in)	Pitch	Flute Length (in)	OAL (in)	# Flutes	Shank Dia. (in)	EDP No.
1/16	0.232	27	0.387	2.25	3	0.313	GFT53106.5782
1/8	0.301	27	0.387	2.25	3	0.313	GFT53106.5783
1/4	0.400	18	0.581	3.25	4	0.500	GFT53116.5784
3/8	0.439	18	0.581	3.25	4	0.500	GFT53116.5785
1/2	0.561	14	0.748	3.50	4	0.625	GFT53136.5786
3/4	0.561	14	0.748	3.50	4	0.625	GFT53136.5787
1" - 2"	0.772	11.5	0.911	3.75	5	0.760	GFT53156.9684

SHUR-THREAD API-LP

Size	Cutter Dia. (in)	Pitch	Flute Length (in)	OAL (in)	# Flutes	Shank Dia. (in)	EDP No.
1/16 - 1/8	0.232	27	0.54	2.25	4	0.313	GFT8B209.9676
1/4 - 3/8	0.400	18	0.80	3.25	4	0.500	GFT8B219.9677
1/2 - 3/4	0.561	14	1.03	3.25	4	0.625	GFT8B239.9678
1" - 2"	0.772	11.5	1.26	3.75	5	0.750	GFT8B259.9679

Cutting Data on page 43.

VARIO

Creates One Pitch in Multiple Thread Sizes

Tools in the VARIO family are full profile thread mills manufactured to cut one specific pitch size but can also produce **more than one thread size**. The term VARIO is a shortened form of VARIOus.

For example, a tool listed as $P=1.25$, $\text{OD} \geq \text{M8}$ can produce an M8 x 1.25 or an M10 x 1.25 thread form with the same tool.

VARIO thread mills also have a larger number of flutes compared to the same style SHUR-THREAD tool. The letter Z is commonly used to signify the number of threads in cutting tool terms. The increased flute count provides a larger core diameter for a more stable cutting action in addition to decreased cut cycle time.

VARIO threading tools require a pre-drilled hole prior to thread milling.

- High flute count from 4 to 8 flutes reduces the cutting load per tooth
- Thicker core design helps improve tool stability and reduce vibration
- Axial coolant-fed design for maximum chip evacuation properties

Cutting Data on page 43.



VARIO Thread Milling Cycle

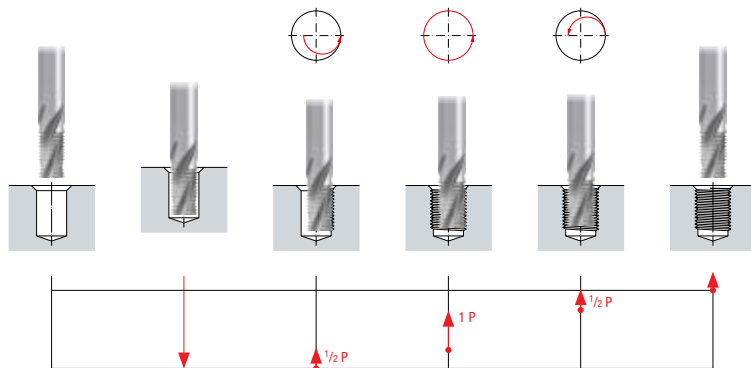

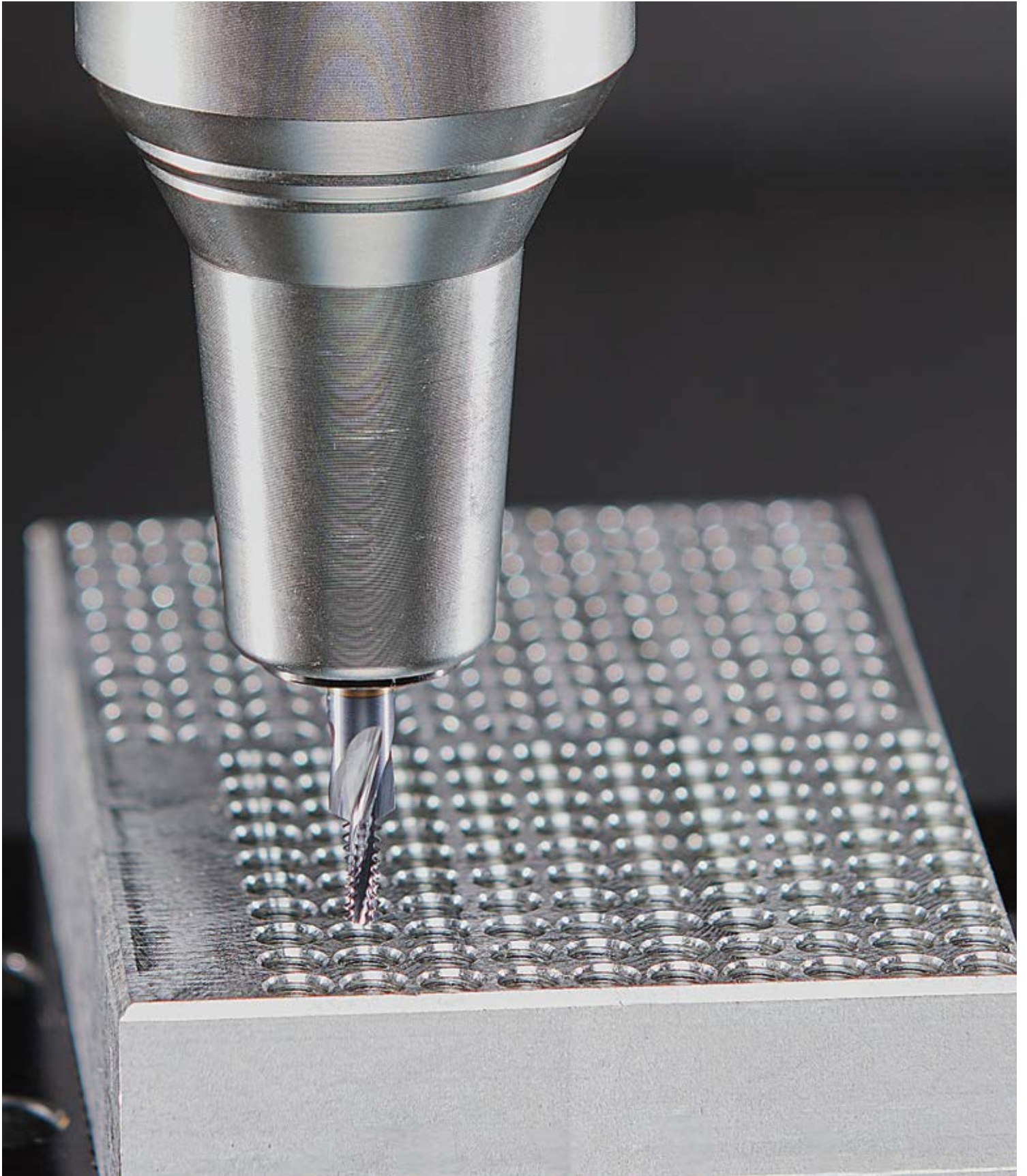

VARIO-Z INTERNAL, is ideal for internal thread milling



VARIO-Z INTERNAL

High Performance Solid Carbide Thread Mill Program

A line of high performance thread mills in a class of its own. Tools feature an increased flute count and core diameter, and multilayered TiCN coating, resulting in reduced vibration, cycle time and tool wear, combined with higher feed rates and improved thread quality.

- **Increased number of flutes** for higher feed rate and reduced cycle times
- **Increased core diameter** for improved radial stiffness and stability
- **Cutting geometry produces smaller chips** that can be removed faster and easier
- **Cutting edges enhanced** for additional strength
- **Advanced multilayer coating** resists heat, edge wear and chipping
- **Extended milling section** for thread depths up to 2XD

2 x D - UNC / UNF - WITH COOLANT-THRU

Thread Size (in)	Thread	Thread Pitch	Cutter Dia. (in)	Length of Cut (in)	# Flutes	OAL (in)	Shank Dia. (mm)	Shank Type	EDP No.
≥ #10	UNC	24	0.145	0.398	4	2.16	6	HB	GFB35106.5007
≥ 1/4		20	0.194	0.524	4	2.28	6	HB	GFB35106.5009
≥ 5/16		18	0.248	0.637	4	2.44	8	HB	GFB35106.5010
≥ 3/8		16	0.301	0.780	5	2.55	8	HB	GFB35106.5011
≥ 7/16		14	0.354	0.890	5	2.91	10	HB	GFB35106.5012
≥ 1/2		13	0.409	1.035	5	3.14	12	HB	GFB35106.5013
≥ 9/16		12	0.464	1.205	5	3.34	12	HB	GFB35106.5014
≥ 5/8		11	0.511	1.314	5	3.54	14	HB	GFB35106.5015
≥ 3/4		10	0.625	1.546	5	3.93	16	HB	GFB35106.5016
≥ 7/8		9	0.744	1.829	6	4.33	20	HB	GFB35106.5017
≥ 1"	8	0.850	2.057	6	4.92	25	HB	GFB35106.5018	
≥ #10	UNF	32	0.153	0.389	4	2.17	6	HB	GFB35106.5041
≥ #12		28	0.175	0.445	4	2.28	6	HB	GFB35106.5042
≥ 1/4		28	0.203	0.515	4	2.28	6	HB	GFB35106.5043
≥ 5/16		24	0.259	0.644	5	2.44	8	HB	GFB35106.5044
≥ 7/16		20	0.375	0.873	6	2.91	10	HB	GFB35106.5046
≥ 9/16		18	0.492	1.136	7	3.35	14	HB	GFB35106.5048
≥ 3/4		16	0.669	1.529	8	4.01	18	HB	GFB35106.5050

- **Axial internal coolant** for superior cooling and chip removal
- **Precision ground** for high repeatability
- Produces threads with **excellent surface finish**

Cutting Data on page 43.



- Higher feed rates
- Reduced cycle times
- Vibration-free machining
- Improved thread quality
- Excellent surface finish

2 x D - METRIC / METRIC FINE - WITH COOLANT-THRU

Thread Size (mm)	Thread Pitch	Cutter Dia. (mm)	Length of Cut (mm)	# Flutes	OAL (mm)	Shank Dia. (mm)	Shank Type	EDP No.
≥ M 3	0.5	2.4	6.2	4	51	6	HB	GFB35106.0030
≥ M 4	0.7	3.15	8.7	4	55	6	HB	GFB35106.0040
≥ M 5	0.8	4	10.8	4	55	6	HB	GFB35106.0050
≥ M 6	1	4.8	12.4	4	55	6	HB	GFB35106.0060
≥ M 8	1.25	6.5	16.8	4	63	8	HB	GFB35106.0080
≥ M 10	1.5	8.2	21.7	5	70	10	HB	GFB35106.0100
≥ M 12	1.75	9.9	25.3	5	74	10	HB	GFB35106.0112
≥ M 14	2	11.6	28.9	5	85	12	HB	GFB35106.0114
≥ M 18	2.5	15	38.6	5	100	16	HB	GFB35106.0118
≥ M 24	3	19.9	49.4	6	115	20	HB	GFB35106.0124

NEW

VARIO-Z External

For Producing External Threads

The VARIO-Z EXTERNAL thread mill is specifically designed to produce external threads in a wide range of materials and applications. These tools have a high number of flutes combined with an enlarged core design to reduce chatter and tool deflection.

No other thread mill design can achieve the tool life or thread quality on external thread parts.

- Right-hand helix with right-hand cut geometry
- Exclusively for the production of external threads
- 2 x D length of cut
- HA cylindrical shank design with h6 tolerance
- Axial coolant fed for optimized chip evacuation
- TiALN-86 coated for heat and wear resistance

Cutting Data on page 43.



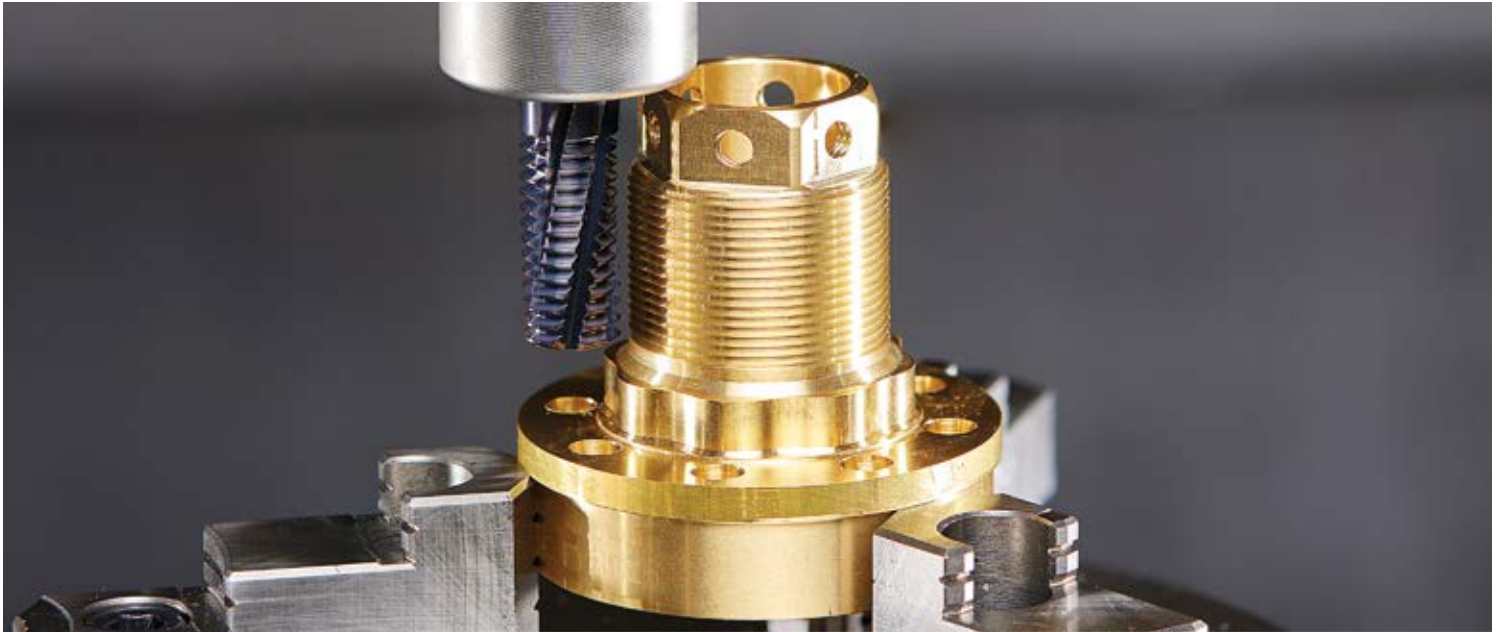

2 x D - UN - WITH COOLANT-THRU

Minimum Diameter	Cutter Dia. (in)	TPI	Shank Dia. (mm)	OAL (in)	Thread Length (in)	# Flutes	EDP No.
0.190" or #10	0.232	32	6	2.165	0.472	6	GF1649CC.9577
0.250" or 1/4	0.311	28	8	2.480	0.630	7	GF1649BC.9578
0.250" or 1/4	0.311	24	8	2.480	0.630	6	GF1649BC.9579
0.250" or 1/4	0.311	20	8	2.480	0.630	5	GF16496C.9580
0.3125" or 5/16	0.390	18	10	2.756	0.787	5	GF16496C.9581
0.3125" or 5/16	0.390	16	10	2.756	0.787	5	GF16496C.9582
0.375" or 3/8	0.469	16	12	3.150	0.984	6	GF16497C.9582
0.375" or 3/8	0.469	14	12	3.150	0.984	5	GF16497C.9583
0.375" or 3/8	0.469	13	12	3.150	0.984	5	GF16497C.9584
0.375" or 3/8	0.469	12	12	3.150	0.984	4	GF16497C.9585
0.5625" or 9/16	0.626	12	16	3.543	1.260	6	GF16498C.9585
0.5625" or 9/16	0.626	11	14	3.543	1.260	5	GF16498C.9586
0.5625" or 9/16	0.626	10	16	3.543	1.260	5	GF16498C.9587



2 x D - METRIC - WITH COOLANT-THRU

Minimum Diameter	Cutter Dia. (mm)	Pitch (mm)	Shank Dia. (mm)	OAL (mm)	Thread Length (mm)	# Flutes	EDP No.
M 5	5.90	0.5	6	55	12	9	GF1649CC.9506
M 5	5.90	0.75	6	55	12	6	GF1649CC.9509
M 5	5.90	0.8	6	55	12	6	GF1649CC.9510
M 6	7.90	1.0	8	63	16	6	GF1649BC.9512
M 8	9.90	1.0	10	70	20	8	GF16496C.9512
M 8	9.90	1.25	10	70	20	6	GF16496C.9513
M 8	9.90	1.5	10	70	20	5	GF16496C.9514
M 10	11.90	1.5	12	80	25	6	GF16497C.9514
M 10	11.90	2.0	12	80	25	5	GF16497C.9516
M 14	15.90	2.0	16	90	32	6	GF16498C.9516
M 14	15.90	2.5	16	90	32	5	GF16498C.9517

VARIO SKIP TOOTH

With Option to Remove the Incomplete Thread

VARIO SKIP TOOTH thread milling cutters with alternating tooth rows are designed to reduce radial forces. The prerequisite for the production of internal threads is a pre-drilled hole and if necessary with a countersink chamfer. Optionally, these tools can also be used to remove the incomplete thread at the start of the thread, at the same time as the thread is machined.

These tools can achieve very long tool life values thanks to an optimized cutting edge geometry and a high number of flutes.

- Significantly reduced radial forces
- Longer tool life values when compared to traditional thread mill designs
- Incomplete thread can be removed as an option
- High process reliability
- No axial miscut thread
- High surface quality of the thread
- High positioning precision
- TIALN-86 coating for heat and wear resistance
- 2.5 x D length of cut

Skip Tooth Thread Milling Cycle

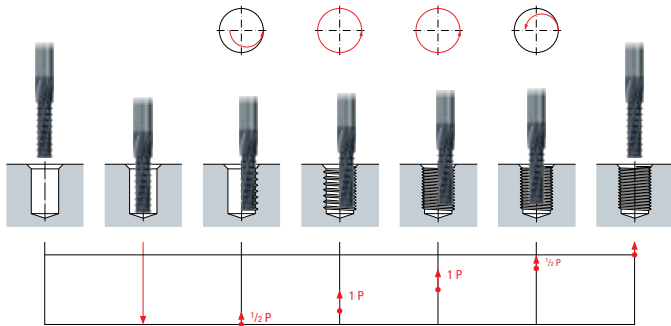

Thread Milling Cycle With Removal of Incomplete Thread

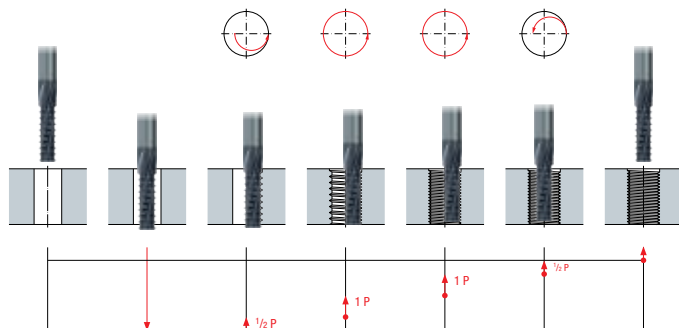

Thread with removed incomplete thread (marked red)

Cutting Data on page 43.

VARIO SKIP TOOTH SOLID CARBIDE THREAD MILLS

2.5 x D - UNC - WITH COOLANT-THRU

TPI	Min. Thread Size (in)	OAL (in)	Cut Length (in)	Cutter Dia. (in)	* Deburr Length (in)	Shank Dia. (mm)	# Flutes	Straight Shank EDP No.	Weldon Shank EDP No.
24	≥ #10	2.283	0.480	0.147	0.539	6	4	GFB4573C.5007	GFB4513C.5007
20	≥ 1/4	2.520	0.673	0.191	0.748	6	4	GFB4573C.5009	GFB4513C.5009
18	≥ 5/16	2.677	0.803	0.248	0.890	8	4	GFB4573C.5010	GFB4513C.5010
16	≥ 3/8	2.835	0.969	0.301	1.063	8	5	GFB4573C.5011	GFB4513C.5011
14	≥ 7/16	3.228	1.106	0.354	1.213	10	5	GFB4573C.5012	GFB4513C.5012
13	≥ 1/2	3.661	1.268	0.409	1.382	12	5	GFB4573C.5013	GFB4513C.5013
12	≥ 9/16	3.858	1.457	0.465	1.583	12	5	GFB4573C.5014	GFB4513C.5014

2.5 x D - UNF - WITH COOLANT-THRU

32	≥ #10	2.283	0.484	0.154	0.531	6	4	GFB4573C.5041	GFB4513C.5041
28	≥ #12	2.362	0.555	0.175	0.606	6	4	GFB4573C.5042	GFB4513C.5042
28	≥ 1/4	2.520	0.661	0.207	0.713	6	4	GFB4573C.5043	GFB4513C.5043
24	≥ 5/16	2.677	0.811	0.260	0.874	8	5	GFB4573C.5044	GFB4513C.5044
20	≥ 7/16	3.228	1.126	0.376	1.201	10	6	GFB4573C.5046	GFB4513C.5046
18	≥ 9/16	3.858	1.417	0.492	1.500	14	7	GFB4573C.5048	GFB4513C.5048

* With option to remove the incomplete thread

2.5 x D - METRIC - WITH COOLANT-THRU

Pitch (mm)	Min. Thread Size (mm)	OAL (mm)	Cut Length (mm)	Cutter Dia. (mm)	* Deburr Length (mm)	Shank Dia. (mm)	# Flutes	Straight Shank EDP No.	Weldon Shank EDP No.
0.7	≥ M 4	55	10.2	3.15	11.2	6	4	GFB4573C.0040	GFB4513C.0040
0.8	≥ M 5	58	13.2	4	14.4	6	4	GFB4573C.0050	GFB4513C.0050
1	≥ M 6	61	15.5	4.8	17	6	4	GFB4573C.0060	GFB4513C.0060
1.25	≥ M 8	68	20.6	6.5	22.5	8	4	GFB4573C.0080	GFB4513C.0080
1.5	≥ M10	78	26.2	8.2	28.5	10	5	GFB4573C.0100	GFB4513C.0100
1.75	≥ M12	84	30.6	9.9	33.2	10	5	GFB4573C.0112	GFB4513C.0112
2	≥ M14	98	37	11.6	40	12	5	GFB4573C.0114	GFB4513C.0114
2	≥ M16	102	41	13.6	44	14	5	GFB4573C.0116	GFB4513C.0116

2.5 x D - METRIC FINE - WITH COOLANT-THRU

1	≥ M 8	68	20.5	6.7	22	8	4	GFB4573C.0251	GFB4513C.0251
1	≥ M10	78	25.5	8.7	27	10	5	GFB4573C.0276	GFB4513C.0276
1	≥ M12	88	30.5	10.6	32	12	7	GFB4573C.0301	GFB4513C.0301
1.25	≥ M12	88	30.6	10.4	32.5	12	6	GFB4573C.0302	GFB4513C.0302
1.5	≥ M12	88	30.7	10.1	33	12	5	GFB4573C.0303	GFB4513C.0303
1.5	≥ M16	110	41.2	14.1	43.5	16	5	GFB4573C.0359	GFB4513C.0359

* With option to remove the incomplete thread



GIGANT-IC™

Indexable Insert Thread Milling System For Producing Large Internal and External Threads

GIGANT-IC is based on lean manufacturing principles and facilitates quick set-ups and rapid changeovers for a wide range of threading applications.

Thread milling cutters of our GIGANT-IC series were developed for the economically efficient production of large and deep threads on modern CNC machines. The GIGANT-IC program is designed in six different sizes, with the goal of achieving the best possible stability of the tools and consequently, trouble-free thread production. This aim is achieved by a choice of different diameters and lengths.

In combination with internal coolant supply and high-performance hard surface coatings, these solid carbide thread milling cutters cover a broad range of machining tasks.

A prepared thread hole, countersunk if necessary, is needed.

Advantages:

- High process safety
- No rejects due to miscut threads
- High surface quality of the threads
- Blind hole threads can be cut down to the bottom of the hole
- High positioning precision
- Low cutting forces
- One tool for all material groups
- Thread production independent of pitch
- Internal coolant supply
- Cuts low- and high-alloyed steels up to 1400 N/mm², stainless steel materials, cast materials, aluminium alloys, copper alloys, magnesium alloys, synthetics as well as titanium alloys.

Cutting Data on page 43.

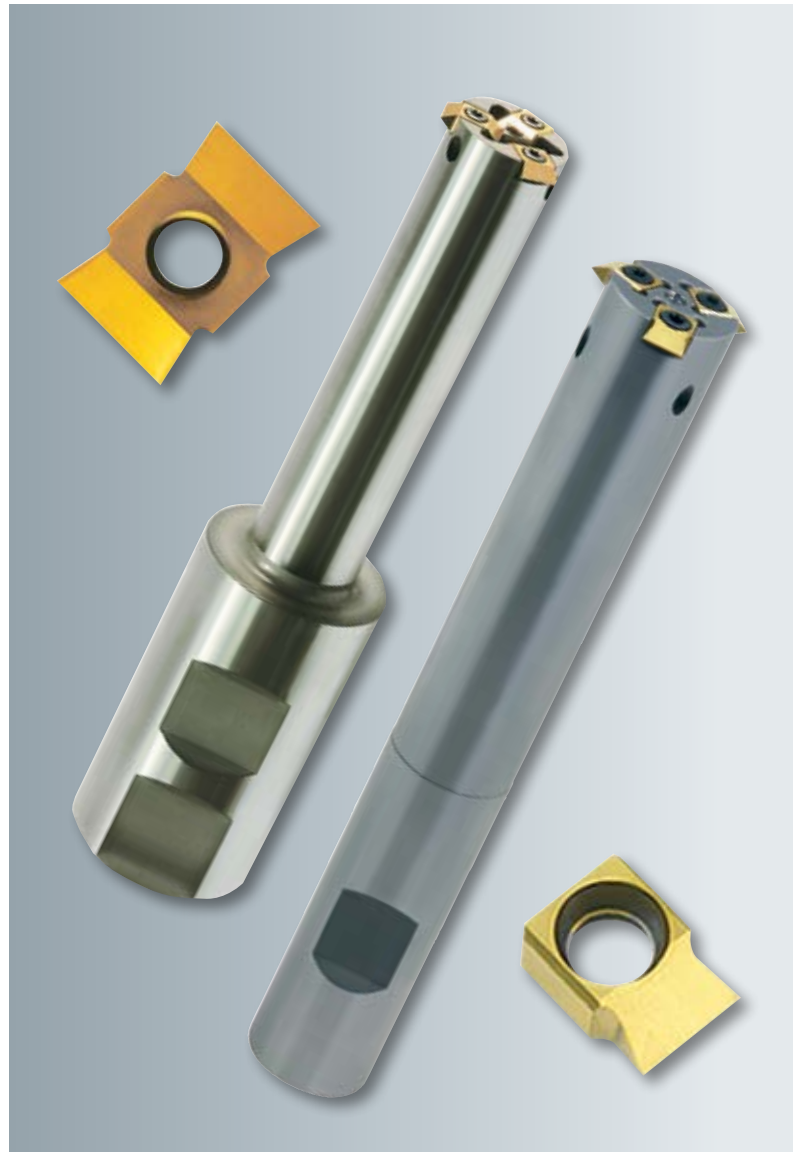

GIGANT-IC Thread Milling Cycle

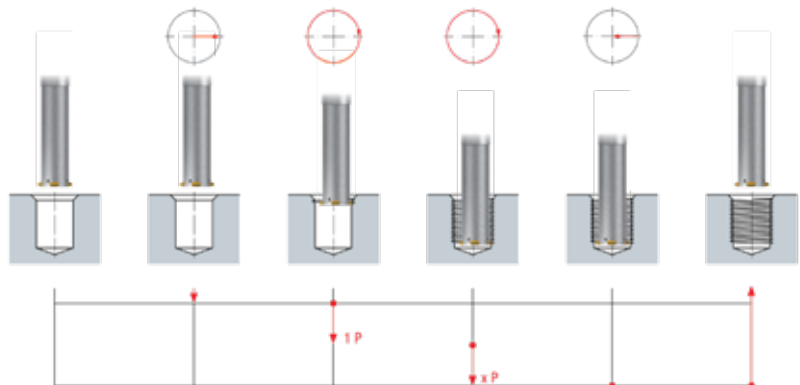



This unique indexable insert thread mill solution provides 4x longer tool life and unsurpassed thread finish quality – the industry’s most versatile system for threads 7/8" – M20 and above.

Styles of Circular Bodies and Inserts



Unique radial exiting coolant

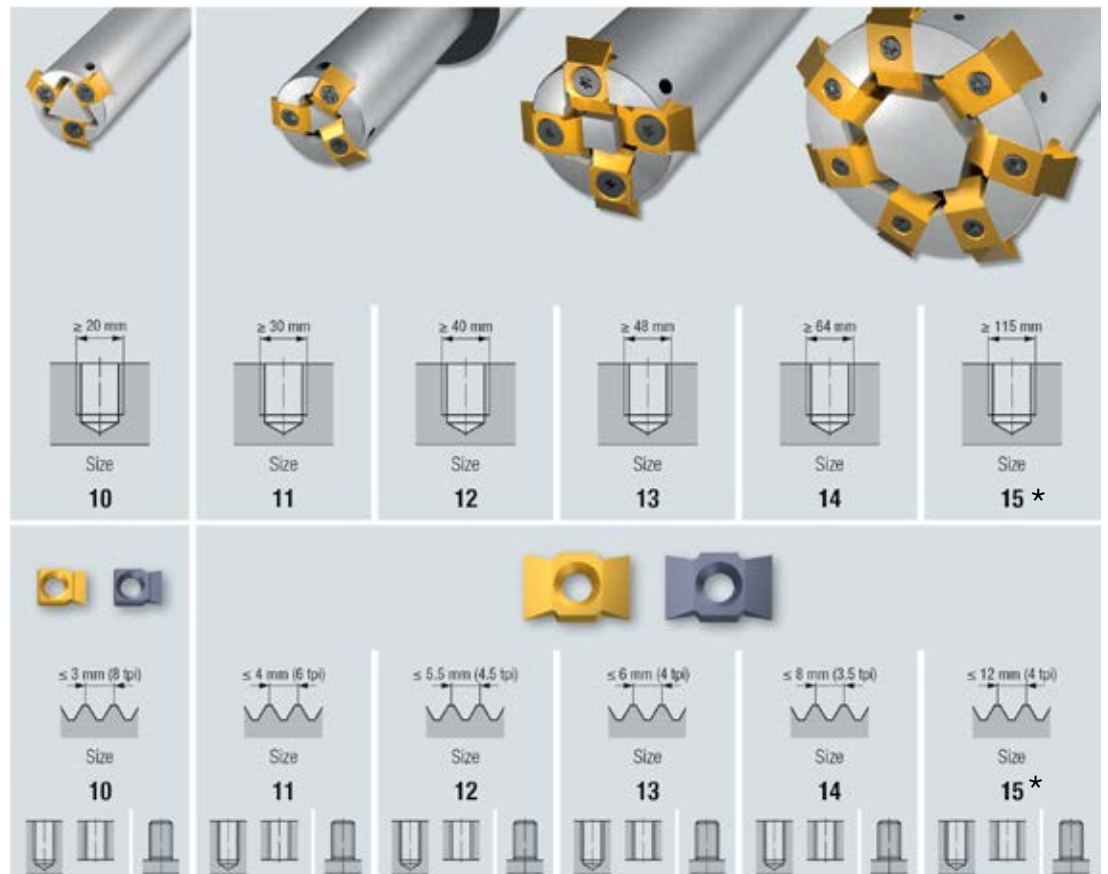

* Size 15 available upon request

GIGANT-IC™ For threads 7/8" – M20 and above, with Coolant-Thru

- **Micro-grain carbide inserts** with advanced cutting geometry and TIN coating allow for easy machining of all difficult materials
- **Modular bar design** allows for 4 bar sizes to be easily set-up and interchanged on a variety of CNC machines with Weldon style shank
- **Fast, easy set-up, programming and maintenance**
- **Rigid, anti-vibration body** design allows for a length-to-diameter-ratio to 2 x D and greater
- **Innovative internal coolant supply** exits radially at the insert cutting edge for optimized cooling, chip evacuation, and thread quality
- **Inserts are rigidly affixed** in a solid steel precision pocket, securely fastened with a Torx locking screw

INSERT BODIES - WITH CAT 50 OR SK 50 SHANK - WITH COOLANT-THRU

Bar Size *	Cutter Dia. (in)	Min. Thread Dia.	Max. Depth L2 (in)	Taper Size	OAL (in)	# Inserts	EDP No.
#13	1.585	2" - M48	4.250	CAT 50	9.620	4	GZ346013
			5.500		11.000		GZ346003
#14	2.069	2 1/2" - M64	7.500	CAT 50	13.000	4	GZ346024
#15 *	3.622	4.5" - M115	8.031	SK 50	13.425	7	GZ344035
			14.173		19.567		GZ344045

* Bar Size 15 available upon request

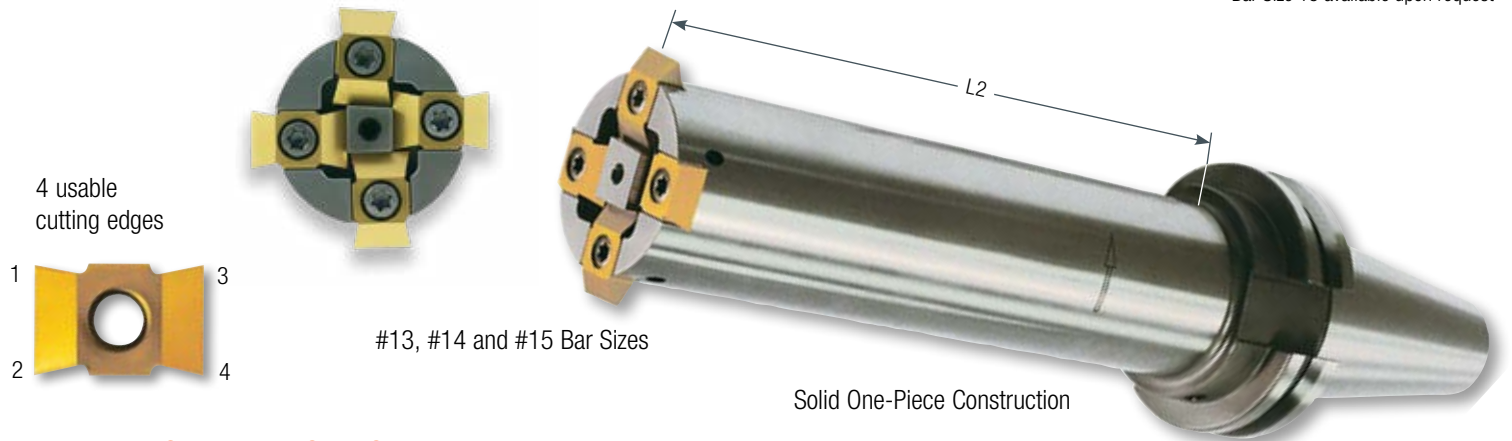

INDEXABLE CARBIDE INSERTS

Insert Size *	Thread Pitch Range				EDP No. TIN COATED	EDP No. TIALN-T4 COATED
	inch	mm	NPT-API	NPSM		
#10	10 - 24	1 - 1.5	–	–	GF643005.9512	GF643007.9512
	8 - 16	1.5 - 3.0	14 - 11 1/2	14 - 11 1/2	GF643005.9514	GF643007.9514
#11	10 - 24	1 - 1.5	–	–	GF643105.9512	GF643107.9512
	10 - 16	1.5 - 2.5	11 1/2	11 1/2	GF643105.9514	GF643107.9514
	6 - 10	2.5 - 4.0	–	8	GF643105.9517	GF643107.9517
#12	10 - 16	1 - 1.5	11 1/2	11 1/2	GF643205.9514	GF643207.9514
	4 1/2 - 10	2.5 - 5.0	–	8	GF643205.9517	GF643207.9517
#13	9 - 16	1.5 - 3.0	8	11 1/2	GF643305.9514	GF643307.9514
	4 - 9	3.0 - 6.0	–	8	GF643305.9518	GF643307.9518
#14	9 - 16	1.5 - 3.0	8	–	GF643405.9514	GF643407.9514
	4 - 9	3.0 - 6.0	–	8	GF643405.9518	GF643407.9518
#15 *	16 - 4	1.5 - 6.0	–	–	GF643505.9514	GF643507.9514
	4	6.0 - 8.0	–	–	GF643505.9523	GF643507.9523

* Inserts Size 15 available upon request

GIGANT-IC INDEXABLE INSERT THREAD MILLING SYSTEM

PVD coated carbide insert application range

TIN – Aluminum, Soft low alloy steels < 25 Rc, Brass, Bronze and Copper

TIALN-T4 – Cast irons, Hard high alloy steels > 25 Rc, Mold and Tool steels, Stainless steels, Titanium, Inconel, Monel and Hastelloy

- **Partial Profile Insert Technology.** Only 2 inserts are required for multiple thread diameters and pitches – UN, UNC, UNF, UNEF, UNJF, UNS, M, MF, MJ, NPT, NPSM, API
- **Rotatable carbide inserts with 4 useable cutting edges provide up to 4x more tool life**
- **Low radial cutting pressure** ensures true-to-gage threads
- **Rigidity, security and precision** provide unsurpassed process consistency and safety for expensive workpieces

INSERT BODIES - WITH WELDON STYLE SHANK - WITH COOLANT-THRU

Bar Size	Cutter Dia. (in)	Min. Thread Dia.	Max. Depth L2 (in)	Shank Dia. (in)	OAL (in)	# Inserts	EDP No.
#10	0.669	7/8" - M20	1.50	1/2	3.42	2	GZ340000
	0.807	1" - M24	2.50	5/8	4.57	3	GZ340050
	0.940	1 1/8" - M30	3.00	1 1/4	5.61	5	GZ340200
#11	0.940	1 1/8" - M30	3.00	1 1/4	5.51	3	GZ340001
	0.940	1 1/8" - M30	3.50	1 1/4	5.91	3	GZ340101
	1.293	1 1/2" - M40	3.50	1 1/4	6.26	5	GZ340201
	1.339	1 3/4" - M40	2.36	1 1/4	4.80	6	GZ340221
#12	1.293	1 1/2" - M40	3.50	1 1/4	6.10	3	GZ340012
	1.293	1 1/2" - M40	4.50	1 1/4	6.89	3	GZ340112
	1.585	2" - M48	4.25	1 1/4	6.77	5	GZ340202
#13	1.585	2" - M48	4.25	1 1/4	6.73	4	GZ340153
	1.585	2" - M48	5.50	1 1/4	8.11	4	GZ340143
	1.893	2 1/4" - M58	6.69	1 1/2	9.55	5	GZ340203

2 usable cutting edges

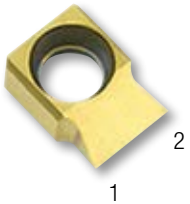

#10 Bar Size

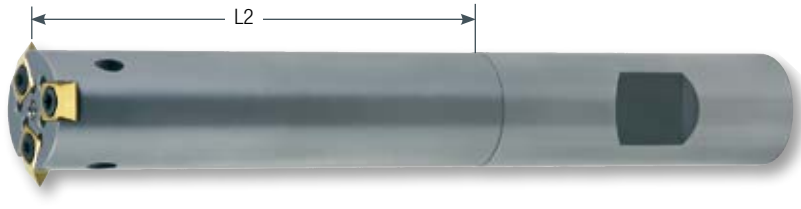

Modular Design - Chuck Sold Separately

4 usable cutting edges

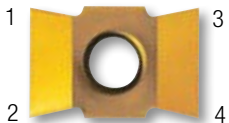

#11, #12, and #13 Bar Sizes

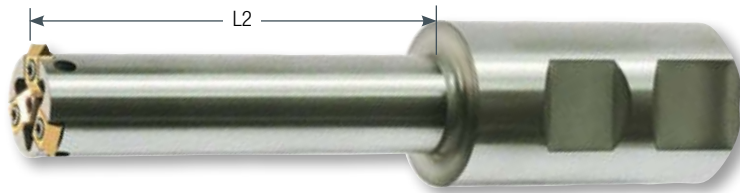

Modular Design - Chuck Sold Separately

THREAD MILL PRODUCT FINDER AND CUTTING DATA

Please note:

The cutting values listed in the respective columns are standard values which need to be adjusted to individual work conditions (material, lubrication, machine etc.).

The suitability is marked as follows:

- Preferred suitable thread mill
- Suitable thread mill

v_c = Cutting speed [SFM]

f_z = Feed per tooth [inch]

f_b = Milling feed [inch/rev.]

Application – Material		Hardness Range			Material Examples		
		HRC	BHN	N/mm ²			
Steel materials							
P	1.1	Cold-extrusion steels, Construction steels, Free-cutting steels, etc.		≤ 180	≤ 600	1010 / 1018 / 1020 / 12L14 / 12L15 / A36 / T1	
	2.1	Construction steels, Cementation steels, Steel castings, etc.	≤ 22	≤ 235	≤ 800	A36 / T1 / 1030-1095 / 4140 / 4340 / 8620	
	3.1	Cementation steels, Heat-treatable steels, Cold work steels, etc.	≤ 31	≤ 295	≤ 1000	4140 / 4340 / 8620 / P20 / H13 / D2 / A2 / S7 / H1150	
	4.1	Heat-treatable steels, Cold work steels, Nitriding steels, etc.	≤ 38	≤ 355	≤ 1200	4140 / 4340 / 8620 / P20 / H13 / D2 / 300M / 52100 / M1-M42	
	5.1	High-alloyed steels, Cold work steels, Hot work steels, etc.	≤ 44	≤ 415	≤ 1400	4140 / 4340 / 8620 / P20 / H13 / D2 / 300M / 52100	
Stainless steel materials							
M	1.1	Ferritic, martensitic	≤ 29	≤ 280	≤ 950	410 / 440 / 440C / 17-4 PH	
	2.1	Austenitic	≤ 29	≤ 280	≤ 950	303 / 304 / 316 / 316L / 321	
	3.1	Austenitic-ferritic (Duplex)	≤ 35	≤ 325	≤ 1100		
	4.1	Austenitic-ferritic heat-resistant (Super Duplex)	≤ 39	≤ 370	≤ 1250		
Cast materials							
K	1.1	Cast iron with lamellar graphite (GJL)		30 - 75	100 - 250	Grey cast irons G10-GG40	
	1.2			75 - 135	250 - 450		
	2.1	Cast iron with nodular graphite (GJS)		105 - 150	350 - 500	Nodular GG640-GGG70	
	2.2			150 - 265	500 - 900		
	3.1	Cast iron with vermicular graphite (GJV)		90 - 120	300 - 400	Compact graphite iron (CGI)	
	3.2			120 - 150	400 - 500		
	4.1	Malleable cast iron (GTMW, GTMB)		70 - 145	250 - 500	White iron	
	4.2			150 - 235	500 - 800		
Non ferrous materials							
Aluminum alloys							
N	1.1	Aluminum wrought alloys		≤ 60	≤ 200	7075	
	1.2			≤ 105	≤ 350	6061-T6 / 2024-T4	
	1.3			≤ 165	≤ 550		
	1.4		Aluminum cast alloys Si ≤ 7%				
	1.5		Aluminum cast alloys 7% < Si ≤ 12%				
	1.6		Aluminum cast alloys 12% < Si ≤ 17%				
Copper alloys							
N	2.1	Pure copper, low-alloyed copper		≤ 120	≤ 400		
	2.2	Copper-zinc alloys (brass, long-chipping)		≤ 165	≤ 550		
	2.3	Copper-zinc alloys (brass, short-chipping)		≤ 165	≤ 550		
	2.4	Copper-aluminum alloys (alu bronze, long-chipping)		≤ 235	≤ 800		
	2.5	Copper-tin alloys (tin bronze, long-chipping)		≤ 205	≤ 700		
	2.6	Copper-tin alloys (tin bronze, short-chipping)		≤ 120	≤ 400		
	2.7	Special copper alloys		≤ 180	≤ 600		
	2.8		≤ 44	≤ 415	≤ 1400		
Magnesium alloys							
N	3.1	Magnesium wrought alloys		≤ 150	≤ 500		
	3.2	Magnesium cast alloys		≤ 150	≤ 500		
Synthetics							
N	4.1	Duroplastics (short-chipping)					
	4.2	Thermoplastics (long-chipping)					
	4.3	Fiber-reinforced synthetics (fiber content ≤ 30%)					
	4.4	Fiber-reinforced synthetics (fiber content > 30%)					
Special materials							
N	5.1	Graphite					
	5.2	Tungsten-copper alloys					
	5.3	Composite materials					
Special materials							
Titanium alloys							
S	1.1	Pure titanium		≤ 135	≤ 450	CP1 / CP2	
	1.2	Titanium alloys		≤ 265	≤ 900	6AL4V	
	1.3		≤ 39	≤ 370	≤ 1250		
Nickel alloys, cobalt alloys and iron alloys							
S	2.1	Pure nickel		≤ 180	≤ 600		
	2.2	Nickel-based alloys		≤ 295	≤ 1000	Monel 500, 718 Inconel annealed	
	2.3		≤ 49	≤ 475	≤ 1600	718 Inconel	
	2.4	Cobalt-based alloys		≤ 31	≤ 295	≤ 1000	
	2.5		≤ 49	≤ 475	≤ 1600	Haynes 25	
	2.6	Iron-base alloys	≤ 46	≤ 445	≤ 1500	Incoloy 925	
Hard materials							
H	1.1	High strength steels, hardened steels, hard castings		44 - 50			
	1.2			50 - 55			
	1.3			55 - 60			
	1.4			60 - 63			
	1.5			63 - 66			

THREAD MILL PRODUCT FINDER AND CUTTING DATA



THREADS-ALL
Pages 6-7

THREADS-ALL / AERO
Pages 8-9

THREADS-ALL / AERO SELF-LOCK
Pages 9

THREADS-ALL / MAX
Pages 10-11

THREADS-ALL / HEADED
Pages 12-13

v_c TICN	f_z		P
	$\phi d_1 \leq 0.1575$	$\phi d_1 \leq 0.3150$	
262 - 820	.0002 - .0016	.0016 - .0028	1.1
197 - 492	.0002 - .0016	.0016 - .0028	2.1
131 - 394	.0002 - .0012	.0012 - .0020	3.1
131 - 394	.0001 - .0008	.0008 - .0020	4.1
131 - 394	.0001 - .0008	.0008 - .0020	5.1
131 - 394	.0001 - .0012	.0012 - .0020	1.1
131 - 394	.0001 - .0012	.0012 - .0020	2.1
98 - 262	.0001 - .0008	.0008 - .0020	3.1
98 - 197	.0001 - .0008	.0008 - .0016	4.1
328 - 656		.0016 - .0028	1.1
328 - 656		.0016 - .0028	1.2
262 - 656		.0016 - .0028	2.1
262 - 656		.0016 - .0028	2.2
262 - 656		.0016 - .0028	3.1
262 - 656		.0016 - .0028	3.2
262 - 656		.0016 - .0028	4.1
262 - 656		.0016 - .0028	4.2
492 - 1312	.0004 - .0020	.0020 - .0031	1.1
492 - 1312	.0004 - .0020	.0020 - .0031	1.2
492 - 1312	.0004 - .0020	.0020 - .0031	1.3
492 - 1312	.0004 - .0020	.0020 - .0031	1.4
492 - 1312	.0004 - .0020	.0020 - .0031	1.5
328 - 656	.0004 - .0020	.0020 - .0031	1.6
492 - 1312	.0003 - .0020	.0020 - .0031	2.1
492 - 1312	.0003 - .0020	.0020 - .0031	2.2
492 - 1312	.0003 - .0020	.0020 - .0031	2.3
328 - 820	.0003 - .0016	.0016 - .0028	2.4
328 - 820	.0003 - .0016	.0016 - .0028	2.5
328 - 820	.0003 - .0016	.0016 - .0028	2.6
131 - 262	.0001 - .0008	.0008 - .0020	2.7
98 - 197	.0001 - .0008	.0008 - .0020	2.8
492 - 1312	.0004 - .0020	.0020 - .0031	3.1
492 - 1312	.0004 - .0020	.0020 - .0031	3.2
328 - 1312	.0004 - .0020	.0020 - .0039	4.1
328 - 1312	.0004 - .0020	.0020 - .0039	4.2
262 - 394	.0004 - .0020	.0020 - .0039	4.3
262 - 394	.0004 - .0020	.0020 - .0039	4.4
328 - 656		.0016 - .0028	5.1
98 - 197		.0008 - .0016	5.2
			5.3
98 - 262	.0001 - .0012	.0012 - .0020	1.1
98 - 262	.0001 - .0012	.0012 - .0020	1.2
98 - 197	.0001 - .0008	.0008 - .0016	1.3
98 - 197	.0001 - .0008	.0008 - .0016	2.1
98 - 197	.0001 - .0008	.0008 - .0016	2.2
98 - 131	.0001 - .0008	.0008 - .0016	2.3
98 - 197	.0001 - .0008	.0008 - .0016	2.4
98 - 131	.0001 - .0008	.0008 - .0016	2.5
98 - 131	.0001 - .0008	.0008 - .0016	2.6
98 - 197		.0006 - .0016	1.1
98 - 197		.0006 - .0016	1.2
			1.3
			1.4
			1.5

v_c = Cutting speed [SFM] f_z = Feed per tooth [inch]



THRILLER
Pages 16-17



THRILLER-AERO
Pages 18-19



THRILLER-MAX
Pages 20-21

	THRILLER		THRILLER-AERO		THRILLER-MAX					
	v_c TICN	f_b $\varnothing d_1 \leq 0.3150$	f_b $\varnothing d_1 > 0.3150$	f_z $\varnothing d_1 \leq 0.3150$	f_z $\varnothing d_1 > 0.3150$	v_c Coated	f_z	v_c Coated	f_z	
P	1.1					492 - 820	.0016 - .0031			
	2.1					492 - 820	.0016 - .0031			
	3.1					328 - 820	.0012 - .0031			
	4.1					328 - 820	.0012 - .0031			
	5.1					328 - 656	.0008 - .0024			
M	1.1					328 - 591	.0008 - .0020			
	2.1					328 - 591	.0008 - .0020			
	3.1					197 - 394	.0008 - .0016			
	4.1					197 - 394	.0008 - .0016			
K	1.1	262 - 525	.0039 - .0098	.0079 - .0157	.0016 - .0028	.0020 - .0047	656 - 984	.0016 - .0039		
	1.2	262 - 525	.0039 - .0098	.0079 - .0157	.0016 - .0028	.0020 - .0047	656 - 984	.0016 - .0039		
	2.1	262 - 525	.0039 - .0059	.0059 - .0098	.0016 - .0028	.0020 - .0047	492 - 820	.0020 - .0031		
	2.2	262 - 525	.0039 - .0059	.0059 - .0098	.0016 - .0028	.0020 - .0047	492 - 820	.0020 - .0031		
	3.1	262 - 525	.0039 - .0098	.0079 - .0157	.0016 - .0028	.0020 - .0047	492 - 820	.0020 - .0031		
	3.2	262 - 525	.0039 - .0098	.0079 - .0157	.0016 - .0028	.0020 - .0047	492 - 820	.0020 - .0031		
	4.1						656 - 984	.0020 - .0039		
	4.2						656 - 984	.0020 - .0039		
N	1.1	492 - 820	.0031 - .0059	.0059 - .0098	.0016 - .0031	.0028 - .0059	656 - 984	.0020 - .0039		
	1.2	492 - 820	.0031 - .0059	.0059 - .0098	.0016 - .0031	.0028 - .0059	656 - 984	.0020 - .0039		
	1.3	492 - 820	.0031 - .0059	.0059 - .0098	.0016 - .0031	.0028 - .0059	656 - 984	.0020 - .0039		
	1.4	492 - 1312	.0059 - .0098	.0079 - .0157	.0016 - .0031	.0028 - .0059	656 - 984	.0020 - .0039		
	1.5	492 - 1312	.0059 - .0098	.0079 - .0157	.0016 - .0031	.0028 - .0059	656 - 984	.0020 - .0039		
	1.6	328 - 656	.0059 - .0098	.0079 - .0157	.0016 - .0031	.0028 - .0059	328 - 656	.0020 - .0039		
	2.1						328 - 591	.0012 - .0020		
	2.2	492 - 1312	.0039 - .0079	.0059 - .0118	.0020 - .0031	.0028 - .0059	492 - 820	.0020 - .0031		
	2.3	492 - 1312	.0039 - .0079	.0059 - .0118	.0020 - .0031	.0028 - .0059	656 - 984	.0020 - .0039		
	2.4						328 - 591	.0012 - .0020		
	2.5						328 - 591	.0012 - .0020		
	2.6	328 - 820	.0039 - .0098	.0079 - .0157	.0016 - .0028	.0020 - .0047	656 - 984	.0020 - .0039		
	2.7								131 - 197	.0008 - .0016
	2.8								131 - 197	.0008 - .0016
	3.1	492 - 1312	.0039 - .0079	.0059 - .0118	.0016 - .0031	.0028 - .0059	656 - 984	.0020 - .0039		
	3.2	492 - 1312	.0059 - .0118	.0079 - .0157	.0016 - .0031	.0028 - .0059	656 - 984	.0020 - .0039		
4.1	328 - 1312	.0059 - .0118	.0079 - .0157	.0020 - .0039	.0031 - .0079	492 - 820	.0020 - .0031			
4.2										
4.3						262 - 492	.0020 - .0031			
4.4						262 - 492	.0020 - .0031			
5.1										
5.2										
5.3										
S	1.1					197 - 394	.0008 - .0016			
	1.2					197 - 394	.0008 - .0016			
	1.3					197 - 394	.0008 - .0016			
	2.1					197 - 394	.0008 - .0016			
	2.2					197 - 394	.0008 - .0016			
	2.3									
	2.4					197 - 394	.0008 - .0016			
2.5										
2.6										
H	1.1					197 - 328	.0008 - .0024	197 - 328	.0012 - .0024	
	1.2					197 - 328	.0008 - .0024	197 - 328	.0012 - .0024	
	1.3							131 - 230	.0008 - .0016	
	1.4							98 - 197	.0008 - .0016	
	1.5							98 - 197	.0008 - .0016	

THREAD MILL PRODUCT FINDER AND CUTTING DATA



SHUR-THREAD
Pages 24-27



VARIO-Z INTERNAL / EXTERNAL
Pages 30-33



VARIO SKIP TOOTH
Pages 34-35



GIGANT-IC
Pages 38-39

v_c TICN	v_c TICN	f_z		v_c Coated	f_z		
		$\phi d_1 \leq 0.1575$	$\phi d_1 \leq 0.3150$				$\phi d_1 > 0.3150$
262 - 820	262 - 820	.0002 - .0016	.0016 - .0028	.0020 - .0059	820 - 1640	.0059 - .0098	1.1
197 - 492	197 - 492	.0002 - .0016	.0016 - .0028	.0020 - .0059	820 - 1640	.0059 - .0098	2.1
131 - 394	131 - 394	.0002 - .0012	.0012 - .0020	.0016 - .0047	492 - 820	.0039 - .0059	3.1
	131 - 394	.0001 - .0008	.0008 - .0020	.0016 - .0047	492 - 820	.0039 - .0059	4.1
	131 - 394	.0001 - .0008	.0008 - .0020	.0016 - .0047	492 - 820	.0039 - .0059	5.1
131 - 394	131 - 394	.0001 - .0012	.0012 - .0020	.0016 - .0047	262 - 492	.0039 - .0059	1.1
131 - 394	131 - 394	.0001 - .0012	.0012 - .0020	.0016 - .0047	262 - 492	.0039 - .0059	2.1
	98 - 262	.0001 - .0008	.0008 - .0020	.0016 - .0039	197 - 394	.0031 - .0047	3.1
	98 - 197	.0001 - .0008	.0008 - .0016	.0012 - .0031	197 - 394	.0031 - .0047	4.1
328 - 656	328 - 656		.0016 - .0028	.0020 - .0059	591 - 1312	.0059 - .0098	1.1
328 - 656	328 - 656		.0016 - .0028	.0020 - .0059	591 - 1312	.0059 - .0098	1.2
262 - 656	262 - 656		.0016 - .0028	.0020 - .0059	591 - 1312	.0059 - .0098	2.1
262 - 656	262 - 656		.0016 - .0028	.0020 - .0059	591 - 1312	.0059 - .0098	2.2
262 - 656	262 - 656		.0016 - .0028	.0020 - .0059	492 - 820	.0039 - .0059	3.1
262 - 656	262 - 656		.0016 - .0028	.0020 - .0059	492 - 820	.0039 - .0059	3.2
262 - 656	262 - 656		.0016 - .0028	.0020 - .0059	591 - 1312	.0059 - .0098	4.1
262 - 656	262 - 656		.0016 - .0028	.0020 - .0059	591 - 1312	.0059 - .0098	4.2
492 - 1312	492 - 1312	.0004 - .0020	.0020 - .0031	.0028 - .0079	1312 - 1640	.0059 - .0118	1.1
492 - 1312	492 - 1312	.0004 - .0020	.0020 - .0031	.0028 - .0079	1312 - 1640	.0059 - .0118	1.2
492 - 1312	492 - 1312	.0004 - .0020	.0020 - .0031	.0028 - .0079	1312 - 1640	.0059 - .0118	1.3
492 - 1312	492 - 1312	.0004 - .0020	.0020 - .0031	.0028 - .0079	1312 - 1640	.0059 - .0118	1.4
492 - 1312	492 - 1312	.0004 - .0020	.0020 - .0031	.0028 - .0079	1312 - 1640	.0059 - .0118	1.5
328 - 656	328 - 656	.0004 - .0020	.0020 - .0031	.0028 - .0079	492 - 820	.0059 - .0118	1.6
492 - 1312	492 - 1312	.0003 - .0020	.0020 - .0031	.0028 - .0079	820 - 1640	.0059 - .0098	2.1
492 - 1312	492 - 1312	.0003 - .0020	.0020 - .0031	.0028 - .0079	820 - 1640	.0059 - .0098	2.2
492 - 1312	492 - 1312	.0003 - .0020	.0020 - .0031	.0028 - .0079	820 - 1640	.0059 - .0098	2.3
328 - 820	328 - 820	.0003 - .0016	.0016 - .0028	.0020 - .0059	492 - 820	.0039 - .0098	2.4
328 - 820	328 - 820	.0003 - .0016	.0016 - .0028	.0020 - .0059	492 - 820	.0039 - .0098	2.5
328 - 820	328 - 820	.0003 - .0016	.0016 - .0028	.0020 - .0059	492 - 820	.0039 - .0098	2.6
131 - 262	131 - 262	.0001 - .0008	.0008 - .0020	.0016 - .0059	262 - 492	.0039 - .0059	2.7
	98 - 197	.0001 - .0008	.0008 - .0020	.0016 - .0059	262 - 492	.0039 - .0059	2.8
492 - 1312	492 - 1312	.0004 - .0020	.0020 - .0031	.0028 - .0079	1312 - 1640	.0059 - .0118	3.1
492 - 1312	492 - 1312	.0004 - .0020	.0020 - .0031	.0028 - .0079	1312 - 1640	.0059 - .0118	3.2
328 - 1312	328 - 1312	.0004 - .0020	.0020 - .0039	.0031 - .0098	591 - 1312	.0059 - .0098	4.1
328 - 1312	328 - 1312	.0004 - .0020	.0020 - .0039	.0031 - .0098	591 - 1312	.0059 - .0098	4.2
262 - 394	262 - 394	.0004 - .0020	.0020 - .0039	.0031 - .0098	262 - 492	.0059 - .0098	4.3
262 - 394	262 - 394	.0004 - .0020	.0020 - .0039	.0031 - .0098	262 - 492	.0059 - .0098	4.4
328 - 656	328 - 656		.0016 - .0028	.0031 - .0098			5.1
98 - 197	98 - 197		.0008 - .0016	.0012 - .0031			5.2
							5.3
98 - 262	98 - 262	.0001 - .0012	.0012 - .0020	.0016 - .0039	197 - 394	.0031 - .0047	1.1
98 - 262	98 - 262	.0001 - .0012	.0012 - .0020	.0016 - .0039	197 - 394	.0031 - .0047	1.2
	98 - 197	.0001 - .0008	.0008 - .0016	.0012 - .0031	197 - 394	.0031 - .0047	1.3
98 - 197	98 - 197	.0001 - .0008	.0008 - .0016	.0012 - .0031			2.1
	98 - 197	.0001 - .0008	.0008 - .0016	.0012 - .0031			2.2
	98 - 131	.0001 - .0008	.0008 - .0016	.0012 - .0031			2.3
	98 - 197	.0001 - .0008	.0008 - .0016	.0012 - .0031			2.4
	98 - 131	.0001 - .0008	.0008 - .0016	.0012 - .0031			2.5
	98 - 131	.0001 - .0008	.0008 - .0016	.0012 - .0031			2.6
	98 - 197		.0006 - .0016	.0012 - .0031			1.1
	98 - 197		.0006 - .0016	.0012 - .0031			1.2
							1.3
							1.4
							1.5



Ask about our
High Precision / Performance FPC
Milling / Drilling / Thread Milling Chucks

SCAN
to Learn
More

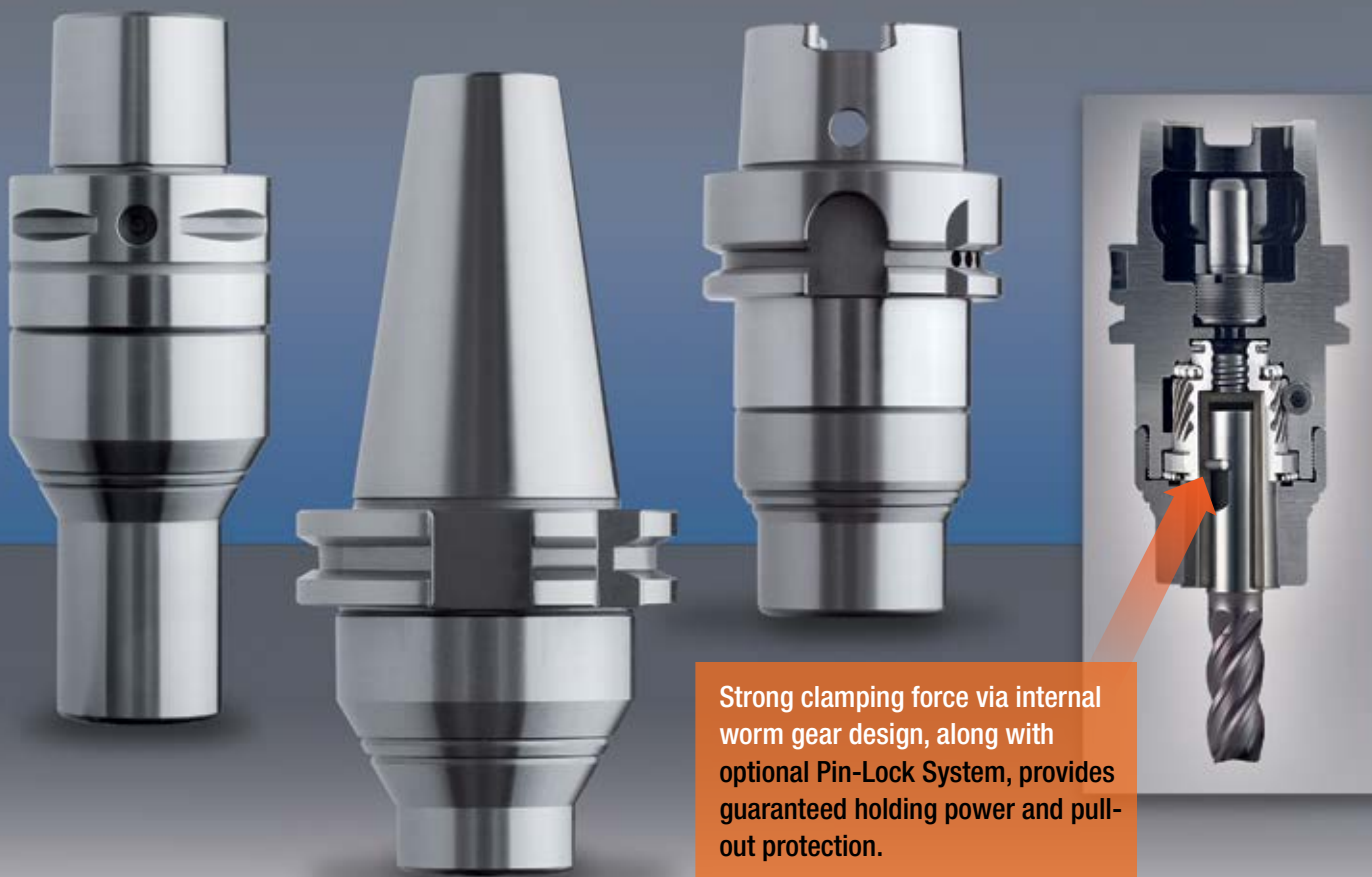

Strong clamping force via internal worm gear design, along with optional Pin-Lock System, provides guaranteed holding power and pull-out protection.



ClineTool.com 866.561.3022

EMUGE-FRANKEN has been the product technology and performance leader in their field for over 100 years. EMUGE-FRANKEN manufactures an extensive line of taps, drills, thread mills, end mills, toolholders, clamping devices and other rotary cutting tools, over 40,000 items sold through distributors worldwide.