



WILLIAMS[®]

 **ClineTool**
An AFC Industries Company

ClineTool.com 866.561.3022

TORQUE SOLUTIONS

A FULL LINE OF PRODUCTS FOR EVERY INDUSTRY

WHY PROPER TORQUE IS SO IMPORTANT!

It's about safety, reliability, and performance. EVERY manufacturer, whether it's in aerospace, motor vehicles, precision equipment, power generation, etc., specifies critical fastener torque for important reasons; under or over tightening critical fasteners can lead to product failure. And product failure means downtime, higher costs, potential injury, and more.

WHAT IS TORQUE?

Torque is rotational or turning force.

Torque is measured in length and force: Length means distance from "center of drive" to "center of handle". Force means "pounds", "Newtons" etc.

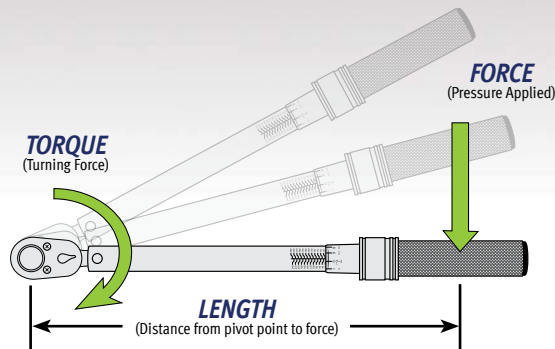

HOW DO YOU CALCULATE TORQUE?

Torque = Length x Force

The standard torque formula used to calculate torque is: "L x F = T"

EXAMPLE: 2 ft. (length) x 30 lbs. (amount of force at center of handle) equals 60 ft. lbs. of torque (60 Ft. Lbs.)

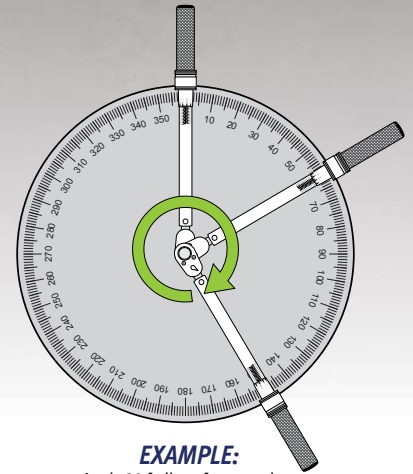

EXAMPLE:

Apply 80 ft. lbs. of torque, then apply 90 degrees of rotation

WHAT IS TORQUE PLUS ANGLE?

Torque Plus Angle creates a more exact clamp load for torque-sensitive equipment.

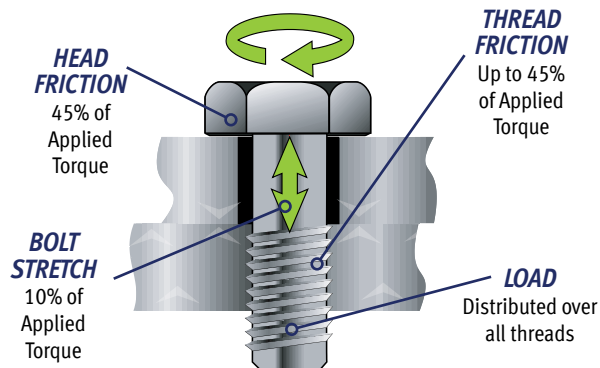

WHAT DOES TORQUE DO?

Torque creates a "Clamp Load" to join two pieces of material.

- Bolts (or threaded fasteners), are designed to create clamping force, also called "clamp load".
- When torque is applied to a threaded fastener, it draws together the joint, (two pieces of material).
- As additional torque is applied to the fastener, the joint is pulled together creating a clamp load as the fastener begins the stretching process. It's this fastener stretch that creates and maintains clamping force, like a stretched bungee cord maintaining tension.
- The actual amount of clamp load is determined by several factors:
 - The amount of torque applied to the fastener.
 - The material and grade of the fastener.
 - The external friction on the joint – friction under the fastener head, and friction between the threads of the fastener and material it's connected to.

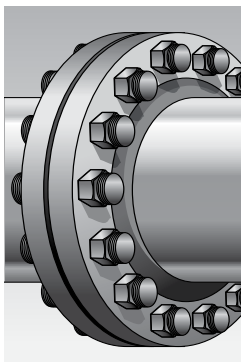

WHY IS APPLYING PROPER TORQUE IMPORTANT?

Creating proper Clamp Load prevents damage and equipment failures.

- Safety & Performance: Applying accurate torque is critical to assembly applications, engines and precision equipment.
- Creating a proper clamp load is the main objective when applying torque to a fastener. Engine cylinder heads, pipe coupling, wheels, all need to be "clamped" uniformly to specific torque values.
- There are three main factors that affect the correct application of torque: (1) Condition of components, (2) Accuracy of torque instrument, (3) Properly applied torque values.
- Applying torque incorrectly can lead to stripped threads, premature loosening or broken fasteners that can cause catastrophic failure. Leaking joints may cause engine or equipment failures.

STRONG.

Quality torque products are designed for dependable long life and accuracy in the most demanding applications.

VALUED.

Every Williams precision torque wrench is hand calibrated and comes with a its own calibration certificate.

WILLIAMS TORQUE PRODUCTS ARE BUILT TO MEET (AND EXCEED) YOUR TORQUE NEEDS

The Williams line of Made-in-USA torque wrenches meets or exceeds ASME standards for high accuracy and repeatability. Every Williams precision torque wrench is hand calibrated and comes with a its own calibration certificate.



Made in U.S.A.

MULTIPLE DRIVES AVAILABLE

1/4", 3/8", 1/2", 3/4" and 1" square drives.

QUICK RELEASE BUTTONS

provide good socket retention as well as easy socket removal

PRECISE

36 Tooth precision reversible ratchet.

LASER MARKED SCALES

are easy to read.

MULTIPLE SCALES AVAILABLE

Available in single scale (in/ft lbs) or dual scale (in/ft lbs and Nm) models.

POSITIVE LOCK

with spring loaded pull down lock ring.

KNURLED GRIP HANDLES

for positive grip retention.



RUGGED PROTECTION

Includes a blow-molded case to protect the wrench when not in use.

HIGHLY ACCURATE +/- 3% of indicated value clockwise from 20% to 100% of full scale.

FULL TORQUE RANGE AVAILABLE from 10-1000 in-lb to 5-1000 ft-lb (1.4 Nm - 1322 Nm).

REDESIGNED INTERNAL MECHANISM

provides improved repeatability and more linear torque between calibration intervals.

INDIVIDUALLY SERIALIZED

with matching certificate of calibration traceable to N.I.S.T.



DID YOU KNOW?

Williams can provide torque training to your staff.

Williams Territory Managers have the knowledge and experience to train your staff on the safe and effective use of Williams Torque Products. Contact your Territory Manager for more information.



EXPLORE AN ENTIRE LINE OF TORQUE PRODUCTS FOR EVERY APPLICATION IN EVERY INDUSTRY.

- 1 ELECTRONIC TORQUE WRENCH**
Designed for professional, exact torquing with speed and more accuracy.
- 2 MICROMETER TORQUE WRENCHES**
Rugged, industrial strength torque wrenches able to withstand the rigors of professional use.
- 3 INTERCHANGEABLE HEAD TORQUE WRENCHES**
Permits ratcheting, fixed or open end torquing capability with adjustable torque wrench bodies.
- 4 SINGLE SETTING TORQUE WRENCHES**
Designed for use on production lines and other applications where a specific torque is required for repetitive operations.
- 5 TORQUE SCREWDRIVERS**
Micro-adjustable For applications that require more than one torque value. Single Setting for high column use in assembly operations.
- 6 PRESET DRIVE TOOLS**
Single setting wrenches for production applications that require higher values than a torque screwdriver can deliver.
- 7 TORQUE ACQUISITION METER**
Portable electronic torque meter that displays torque readings from sensors that attach between sockets and drivers.



ALL WILLIAMS TORQUE PRODUCTS ARE PROUDLY MADE IN THE USA.

Made in U.S.A.



ASK ABOUT OUR MODULAR INDUSTRIAL STORAGE.

VIEW OUR ENTIRE CATALOG OF WILLIAMS INDUSTRIAL TOOLS



WILLIAMS-INDUSTRIAL.COM

USA: 800-446-7404

Canada: 800-296-4787



TRAIN WITH THE BEST - Williams Territory Managers have the knowledge and experience to train your employees on the safe and effective use of Williams' Torque Products. Contact your Territory Manager for more information.

Williams is a trademark of Snap-on Incorporated. © Snap-on Incorporated 2021. All other marks are trademarks of their respective holders. Snap-on Industrial, 2801 80th Street, Kenosha WI 53143



ClineTool

An AFC Industries Company

ClineTool.com 866.561.3022